

## USE AND MAINTENANCE HANDBOOK

UK

### P-SF-SV



# RIVACOLD

MASTERING COLD





Name of Manufacturer:

Rivacold s.r.l.

Address:

Via Sicilia, 7

Fraz. Montecchio 61022 VALLEFOGLIA (PU)

Telephone:

(+39) 0721 919911

Fax:

(+39) 0721 490015

## RIVACOLD S.R.L. – ALL RIGHTS RESERVED

This Use and Maintenance Handbook is entrusted to users of BLOCKSYSTEM P-SF-SV, to instruct the technicians responsible for maintenance and operators. The instructions, drawings, tables and any other contents of this handbook are of a confidential technical nature and cannot be reproduced and/or divulged, completely or in part, without the specific written authorisation of RIVACOLD S.R.L.

It is explicitly forbidden for technicians and operators responsible for maintenance and operations to diffuse the information contained in this handbook or use it for purposes other than those closely linked to the good conservation of the BLOCKSYSTEM P-SF-SV, its use and maintenance.

RIVACOLD S.R.L cannot be held responsible or prosecuted for damages caused by the incorrect use of the documentation. To avoid incorrect operations which could be dangerous to people, it is important to read and understand all the documentation supplied with the BLOCKSYSTEM P-SF-SV.

## INDEX

<b>1 General information</b>	<b>Pag. 03</b>
1.1 General information	Pag. 03
1.2 Property of information	Pag. 03
1.3 Contents of use and maintenance handbook	Pag. 03
1.4 Convention and definitions	Pag. 04
1.5 Warranty	Pag. 06
1.6 Support	Pag. 06
<b>2 Machine description</b>	<b>Pag. 07</b>
2.1 Control panel	Pag. 07
<b>3 Safety and technical data</b>	<b>Pag. 08</b>
3.1 Safety general information	Pag. 08
3.2 Protection device and solutions	Pag. 08
3.3 Residual risk Warnings	Pag. 08
3.4 Safety signs	Pag. 11
3.5 Work Area and position of the operator	Pag. 12
3.6 Noise and vibration indications	Pag. 12
3.7 Proper and improper use of the machine	Pag. 12
3.8 General warnings and behavioural norms	Pag. 12
3.9 Machine data and technical features	Pag. 13
3.10 Technical data and overall dimensions	Pag. 13
<b>4 Transport and installation</b>	<b>Pag. 14</b>
4.1 General information	Pag. 14
4.2 Transportation and movement	Pag. 14
4.3 Installation	Pag. 15
4.4 Storage	Pag. 18
<b>5 Machine use</b>	<b>Pag. 18</b>
5.1 Machine use	Pag. 18
5.2 Alarm signals	Pag. 23
<b>6 Maintenance and demolition</b>	<b>Pag. 24</b>
6.1 General maintenance information	Pag. 24
6.2 Emergency system	Pag. 25
6.3 Cleaning and maintenance	Pag. 26
6.4 Out of service, dismantling and demolition	Pag. 27
<b>7 Optional</b>	<b>Pag. 27</b>
<b>8 Faults search</b>	<b>Pag. 28</b>
<b>9 Attachments</b>	<b>Pag. 30</b>

# 1. General Information

## 1.1. General Information

This Use and Maintenance Handbook is an integral part of the BLOCKSYSTEM P – SF - SV (identified, in this document, with the term MACHINE) manufactured by RIVACOLD SRL ; for this reason, it must accompany the MACHINE if transferred to a new user or owner. This handbook must be carefully stored and protected from any agents which could cause its deterioration, for the entire lifecycle of the machine.

This handbook was drafted for the purpose of providing operators and technicians responsible for the maintenance of the machine with the essential information and instructions to correctly operate the machine in safe conditions.



**ATTENTION:** Please keep this manual in a safe and accessible place for use as an immediate reference by any operator or engineer.

This handbook contains all the data and information necessary for preliminary training of staff responsible for managing the MACHINE correctly; for this purpose, its use is compulsory.



**DANGER:** for clarity, some illustrations in this handbook show the machine or its components when opened or dismantled; it is however forbidden to use the machine in such conditions.

Even though all the attention notes and warnings for correct use of the MACHINE by the operators have been highlighted or to enable staff responsible for maintenance to intervene correctly, this handbook assumes that, in the environments in which the MACHINE is installed, all norms in force are complied with in relation to safety and hygiene in the workplace matters and that staff responsible for operation and maintenance have a level of training that allows them to correctly interpret the information reported.



**NOTE:** the user can request a copy of this document (for example, in case of damage to the original document) by making a written request to the Manufacturer's Technical Office (see Paragraph 1.6.1 – Request for Support in this chapter), making a commitment, in any case, to replace the damaged copy.

## 1.2. Property of information

This Use and Maintenance Handbook contains confidential information.  
All rights reserved.

This handbook cannot be reproduced or photocopied, all or in part, without the prior, written consent of the manufacturer. Use of this documentation material is only permitted to the client to whom the handbook was provided with the machine and only for purposes of installation, use and maintenance of the machine to which the handbook refers.

The manufacturer declares that the information contained in this handbook complies with the technical and safety specifications of the machine to which the handbook refers. The drawings, diagrams and technical data reported are updated on the date of publication of this document and are exclusively valid for the machine to which they are attached.

The manufacturer reserves the right to make changes or improvements without prior notice to this documentation material.

The manufacturer does not assume any responsibility for direct or indirect damage to persons, property or domestic animals as a result of use of this documentation material or the machine in conditions other than those planned.

## 1.3. Contents of the Use and Maintenance Handbook

This Maintenance Handbook is for use by operators and technicians to allow them to understand and correctly use the MACHINE.

This handbook, in fact, other than a functional description of the MACHINE and its main parts, also contains the instructions and indications to:

- ▶ transport and install the MACHINE correctly;
- ▶ correctly use the MACHINE;
- ▶ conduct correct cleaning, regulation and maintenance of the MACHINE;
- ▶ pay attention to the fundamental safety and accident prevention regulations.

The aforementioned staff will therefore have the chance to understand the potential of the MACHINE and the problems that may arise during its management.

It is necessary to carefully read all the chapters to understand the instructions provided in this handbook and to operate the MACHINE; for subsequent, easy searches of the contents, refer to *Table 1*, containing a description of the topics covered in the chapters.

**Table 1 – Layout of Use and Maintenance Handbook**

CHAPTER	CONTENTS	RECIPIENTS
Chapter 1 General Information	<ul style="list-style-type: none"> <li>▶ Description of this use and maintenance handbook, of its layout and the conventions used;</li> <li>▶ definition of the terms used;</li> <li>▶ definition of the relationship between the manufactures and the purchaser/user (in terms of the <b>warranty and support conditions</b>).</li> </ul>	All staff using the MACHINE.
Chapter 2 Machine description	<ul style="list-style-type: none"> <li>▶ Description of the MACHINE and its functioning.</li> </ul>	All staff using the MACHINE.

CHAPTER	CONTENTS	RECIPIENTS
Chapter 3 Safety and Technical Data	<ul style="list-style-type: none"> <li>➤ Presentation of general indications for the MACHINE, on the solutions implemented to protect operator staff, <b>on generic warnings to comply with to correctly</b>, use the machine and the residual risks present during the phases of the life cycle of the MACHINE;</li> <li>➤ presentation of the main <b>technical data</b> concerning the MACHINE.</li> </ul>	All staff using the MACHINE (in particular, the mechanic and electric maintenance workers and the personnel appointed to its handling).
Chapter 4 Transportation and Installation	<ul style="list-style-type: none"> <li>➤ Description of the <b>lifting and transportation</b> modes of the MACHINE;</li> <li>➤ description of the modes of connection to the power supply and of the appliances;</li> <li>➤ description of the <b>storage</b> modes of the MACHINE.</li> </ul>	All staff using the machine (in particular the mechanic and electric maintenance workers, the technicians of the Producer, and the personnel appointed to handling.)
Chapter 5 Machine use	<ul style="list-style-type: none"> <li>➤ Description of the procedures to follow in order to <b>use</b> the MACHINE.</li> </ul>	All staff using the MACHINE.
Chapter 6 Maintenance and Demolition	<ul style="list-style-type: none"> <li>➤ Description of the <b>verification and control</b> procedures of the parts and the components of the MACHINE (in particular, the parts most subject to wear out);</li> <li>➤ description of the procedures that allow the appointed personnel to perform the <b>cleaning</b> of the MACHINE;</li> <li>➤ presentation of the indications to perform the <b>dismantling, demolition, and disposal</b> of the MACHINE.</li> </ul>	All staff using the machine (in particular the mechanic and electric maintenance workers, the technicians of the Producer, and the personnel appointed to handling.)
Chapter 7 Optional	<ul style="list-style-type: none"> <li>➤ Description of the possible optional features that can be installed on the MACHINE.</li> </ul>	All staff using the MACHINE.
Chapter 8 faults search	<ul style="list-style-type: none"> <li>➤ List of the possible malfunctions of the machine and the relative solutions.</li> </ul>	All staff using the MACHINE.
Chapter 9 Attachments	<ul style="list-style-type: none"> <li>➤ <b>Indications for the retrieval of the:</b> technical sheet of the MACHINE, refrigerant diagram, electrical wiring diagram of the MACHINE, documentation of the components present on the MACHINE.</li> </ul>	All staff using the MACHINE.

## 1.4. Convention and Definitions

### 1.4.1. General Information

The Use and Maintenance Handbook of the MACHINE was divided into chapters to enable, for each phase of the MACHINE life (transport, installation, use, regulation, maintenance and decommissioning), easy availability of relative necessary information for the user of the MACHINE.

All the documentation relating to the MACHINE was drafted by developing the topics indicated by the Machinery Directive (2006/42/EC), PED Directive (97/23/CE) and the safety norms in force; therefore, the *complete reading of all the relative material* is indispensable to obtain the best performance from the MACHINE and ensure maximum duration of all its units.

The configuration of certain units or devices described or shown in the documents can differ from that in the MACHINE in the specific preparation according to particular requirements or safety norms; in this case, certain descriptions, references or procedures recommended can be generic in order to maintain their efficiency. Drawings mentioned or photographs are provided for example purposes as a reference for easy comprehension of the text.

### 1.4.2. Term conventions

MACHINE: the term used in this Use and Maintenance Handbook to indicate the BLOCKSYSTEM SERIES P OR SF OR SV.

IPD: the acronym indicates Individual Protection Device/s.

### 1.4.3. Definitions

DANGER ZONE	Any ZONE inside or near the MACHINE in which the presence of an exposed person composes a risk to the safety and health of that person.
USER	Any PERSON (business person/company) adequately using the MACHINE or that assigns its use or operations connected to use to trained people.
EXPOSED PERSON	Any PERSON located inside or partly in the danger zone or near these zones.
OPERATOR	Staff, generally without specific skills, that conduct the operations necessary to operate the MACHINE and clean the MACHINE and the place in which it is installed; if necessary, the operator can conduct simple regulation and restore of functioning operations on the MACHINE.
MECHANICAL MAINTENANCE PERSON	QUALIFIED TECHNICIAN who can intervene on any mechanical unit to regulate or repair it and conduct the necessary maintenance operations. The mechanical maintenance person is not enabled to conduct intervention on the electrical systems when voltage is present.
ELECTRICAL MAINTENANCE PERSON	QUALIFIED TECHNICIAN responsible for all electrical intervention (regulation, maintenance and repairs) and, when necessary, works with voltage present inside the electrical cabinets and the shunt boxes.
MOVEMENT STAFF	QUALIFIED STAFF that perform the tasks of moving the MACHINE or the materials used if the operation requires the use of lifting devices.

MANUFACTURER TECHNICIAN	QUALIFIED TECHNICIAN made available by the manufacturer of the MACHINE to conduct complex operations in particular situations or, however, when agreed with the user.
-------------------------	---

### 1.4.4. Individual Protection Devices and Behaviour Norms

For each of the operations described in this handbook, the individual protection devices were indicated for responsible staff which must be used (if necessary, in addition to those staff must wear when installing the MACHINE) and the behaviour norms that enable operator safety to be safeguarded.



**NOTE:**

Paragraph 3.8 – General Warnings and Behaviour Norms in Chapter 3 – Safety and Technical Data in particular reports a series of general recommendations to comply with to avoid risk conditions for people or damage to the machine.

### 1.4.5. Machine status

The status of the MACHINE is the feature that describes both the functioning mode (for example, on and off) and the safety conditions present (for example, guards included, guards excluded and electrical power sectioning).

### 1.4.6. Typographic conventions

The graphical settings of this Use and Maintenance Handbook enable *easy recognition of contents*; in this optic, for example, the instructions are associated with lists, indicated as follows:

- ▶ this symbol identifies a generic pointed list or a pointed list formed by simple actions (the order in which the actions are presented is not binding, but recommended);
- 1. in this way an explanatory numbered list identifies a complex procedure (the order in which the actions are presented is binding to correctly and safely conduct the intervention in question).

Text in *Italics* is used, in particular for:

- ▶ cross references; cross references used in this handbook are expressed in the following format: "Paragraph/Figure/Table" with the number and, generally, the specification of the "Chapter" with the number and relative name (when not specified it is assumed the paragraph, table or figure belongs to the current chapter);
- ▶ technical and specialist terms, the first time they appear in the text;
- ▶ foreign terms not commonly used (they too, usually only the first time they appear in the text).

**Bold text** is used to highlight words, sentences or parts of procedures.

In the description of the MACHINE, its components, its use and maintenance, explanatory figures of the portion in question are used and these identify the specific points of interest, with the following notation:

number	Symbolic representation of a command or signalling device (for example, buttons, selectors or indicator lights).
letter or number	Symbolic representation of a part of the MACHINE.

Furthermore, to guarantee more in-depth knowledge of the MACHINE and the indications for its correct and safe use, the text of this Use and Maintenance Handbook comes with indications that complete it, providing additional news, indispensable attention or danger notes that are particularly significant to consider; the following notation is used in relation to this:



**NOTE:**

indicates the notes, the warnings, the suggestions and other points the reader should pay attention to or complete the explanation with further news.



**ATTENTION:**

indicates situations or operations where there is a valid possibility of causing damage to the machine, the equipment connected to it or the environment.



**DANGER:**

indicates situations or operations which must be followed or information to which particular attention must be paid to avoid harming people.

### GRAPHIC SYMBOLOGY USED TO INDICATE THE NEED FOR INDIVIDUAL PROTECTION DEVICES

This paragraph indicates the graphic symbols used in this handbook to indicate the need to wear certain IPD.



Indicates the need to use suitable head protection to conduct the operation described.



Indicates the need to use suitable protective gloves to conduct the operation described (possibly dielectric to conduct electrical system intervention).



Indicates the need to use suitable protective clothing to conduct the operation described.



Indicates the need to use suitable safety footwear to conduct the operation described.



Indicates the need to use suitable protective goggles to conduct the operation described.

## 1.5. Warranty

### 1.5.1. General Conditions

The manufacturer, RIVACOLD SRL, guarantees the BLOCKSYSTEM SERIES P – SF –SV and its equipment manufactured by the same manufacturer as being free of material and manufacturing defects for a period agreed and stipulated in the sales contract of the MACHINE.

### 1.5.2. Parts excluded from warranty

The warranty excludes pieces that wear and all consumable tools and materials possibly supplied by the manufacturer with the MACHINE.

### 1.5.3. Responsibility of the User

The client is responsible for:

- electrical system set-up;
- consumable tools and materials.

### 1.5.4. Operations causing warranty invalidity

Any attempt to dismantle, modify or tamper with a MACHINE component by the user or by unauthorised staff leads to the warranty becoming invalid and removes the manufacturer from any responsibility regarding possible damage to persons or property deriving from such tampering.

The manufacturer is also removed from possible responsibility and the warranty is invalid for the MACHINE in the following cases:

- unplanned use of the MACHINE (see Paragraph 3.6 – Proper and improper use of the machine Chapter 3 – Safety and Technical Data);
- use contrary to requisites in norms in force in the country of use;
- installing the MACHINE in conditions other than those specified in Chapter 4 – Transport and Installation;
- connections non-conforming to specifications reported in Chapter 4 – Transport and Installation;
- use of work equipment other than those specified in Chapter 5 – Machine Use and in Chapter 6 – Maintenance and Demolition;
- total or partial non-compliance with the instructions reported in this handbook;
- no or incorrect maintenance;
- use of non-original parts or those not specified by the manufacturer.

## 1.6. Support

Regarding maximum use of the performance provided by the MACHINE and the extraordinary maintenance operations, this handbook does not replace the experience of the installers, users or maintenance staff that is trained and qualified.

On the subject, the Technical Support Service of RIVACOLD SRL provides:

- telephone support on the features and simplest interventions to conduct on the MACHINE;
- sending of documentation material;



#### ATTENTION:

*in case of doubt on the correct interpretation of instructions in this Use and Maintenance Handbook, contact the Technical Support Service (as indicated below) to obtain the NECESSARY clarifications.*

### 1.6.1. Intervention Support Requests

To contact the Technical Support Service contact the:

Technical Office of Rivacold s.r.l.  
Via Sicilia, 7  
Fraz. Montecchio 61022 VALLEFOGLIA (PU)  
Italy  
Telephone: (+39) 0721 919911  
Fax: (+39) 0721 490015  
E mail: ufficiotecnico@rivacold.com

During the requests for support, specify the name, model and registration of the machine.

## 2. Machine description

The machine represents a refrigerating unit composed of a condensing unit (coldroom exterior), an evaporating unit (coldroom interior) and an electronic control panel located inside the condensing unit. The refrigerant follows the compression refrigerating cycle system. The machine can be equipped with a hot gas defrosting system (MBP and LBP), a ventilation defrosting system (HBP) or an electrical defrosting system, which is run with an electronic control unit. Defrosting occurs automatically with a cyclical frequency that can be controlled by the user; it can be activated, also manually, using the relevant control.

This solution allows you to have a product that is easy to use, simple to install and offering maximum versatility. The use of state of the art technological solutions has enabled optimisation of the dimensions of the machines, improving their installation modes, especially on the compact coldrooms.

The PT model is a wall Blocksystem for the refrigeration of coldrooms from 2 HP to 20 HP. Specifically, the P model comes in a plug-in (PT) or saddle version (PA).

The SF model is a ceiling Blocksystem for the refrigeration of coldrooms from 1/3 HP to 4 HP.

The SV model is a wall Blocksystem for the refrigeration of coldrooms from 3/7 HP to 1.5 HP.

### 2.1. Control panel

Below (Table 2) reports the description of the commands on the management software.

Figure 1 Control panel

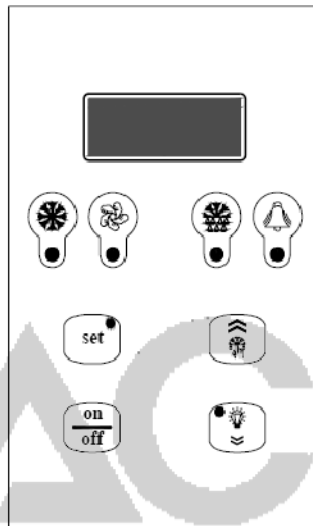





Table 2 – commands descriptions.

SIMBOL	DESCRIPTION
	Green "COMPRESSOR" LED OFF: The compressor is off LIT: The compressor is operating. BLINKING: The switch on request is pending (delays or protective devices activated)
	Green "FANS" LED OFF: The fans are off LIT: The fans are operating BLINKING: The switch on request is pending (delays or protective devices activated)
	Green "DEFROSTING" LED OFF: Defrosting is not activated LIT: Defrosting is in progress BLINKING: Manual defrosting is in progress; a defrosting request is pending (delays or protective devices activated); network synchronised (master/slave) defrosting
	Yellow "ALARM LED" OFF: No alarm is in progress LIT: A serious alarm is in progress (and alarm relay activated) BLINKING: A non-serious alarm is in progress or a serious alarm has been silenced (alarm relay deactivated)
	"SETPOINT" key + "SETPOINT/REDUCED SET" green LED LIT: The setpoint is displayed BLINKING: The reduced set is activated ENTER" key: This is used to set the setpoint, to access the programming menu, and to view the machine status (if held down for 1 second); to enter the programming mode, this key must be held down for 5 seconds.

SIMBOL	DESCRIPTION
	"UP" key: This is used to command manual defrosting (if held down for more than 5 seconds) as well as to increase the value of the parameter being displayed and to scroll forwards through the menu list.
	"ON/OFF" key: This is used as a manual on-off control, to confirm a parameter value and it also allows you to return to the previous menu. To switch the machine on or off, hold this key down for more than 5 seconds.
	"DOWN" key: This is used to command the lights manually (if held down for 1 second); it also decreases the value of the parameter being displayed and scrolls back through the menu list.

## 3. Safety and Technical Data

### 3.1. Safety General Information

#### 3.1.1. Engineering Criteria

For the machine design, the principles and concepts introduced in the relevant paragraphs of the norms indicated in *Table 3* were implemented.

**Table 3 – Main norms used in the machine design.**

NORM	TITLE
UNI EN ISO 12100-1: 2009	Safety of the machinery - Key concepts, general engineering principles - Part 1: Base terminology, methodology
UNI EN ISO 12100-2: 2009	Safety of the machinery - Key concepts, general engineering principles - Part 2: Technical principles
UNI EN ISO 14121-1: 2007	Safety of the machinery - Evaluation of the risks - Part 1: principles
UNI EN ISO 13857: 2008	Safety of the machinery - Safety distances to prevent upper and lower limbs from reaching dangerous areas
UNI EN 953: 2009	Safety of the machinery - Guards - General requisites for the engineering and the construction of the fixed and mobile guards
CEI EN 60204-1: 2006	Machinery safety – Electrical equipment on the machine - Part 1: General rules:
CEI EN 60335-1: 2008	Safety of the electrical equipment intended for domestic use and other similar equipment - Part 1: General norms

The compliance of the paragraphs to the aforementioned norms has enabled risks to be eliminated or reduced as much as possible, both during normal functioning and during regulation and maintenance operations, for the entire lifecycle of the machine.

The components used were carefully chosen among those available on the market and the materials composing the machine (and the machine accessory tools) present no risks to personal health and safety. All the parts provided by third parties are CE marked (when planned) and comply with the relevant reference directives. All the details were closely controlled in compliance with the qualitative standards prescribed by the laws in force.

For the machine, the warning and protection measures were also implemented that are necessary to confront residual risks (see *Paragraph 3.3 – Residual Risk Warnings* on this).

### 3.2. Protection Devices and Solutions

#### 3.2.1. Passive Safety Devices

The machine includes implemented devices and construction solutions as described below.

- Fastened guards, on all sides of the machine, which enclose the entire body of the machine.
- Fastened guards in metal or plastic mesh over the mobile units.
- Safety signs corresponding to the machine protections.

#### 3.2.2. Active Safety Devices

The machine includes active safety devices as described below.

- Safety pressure switch on the compressor
- Security valve (when provided)

### 3.3. Residual Risk Warnings

To avoid all dangerous conditions for people or damage to the machine caused by residual risks, i.e. those risks that persist despite all the devices implemented, or potential risks that are not obvious, the manufacturer recommends the operators, maintenance staff and all staff working on the machine scrupulously follow the warnings on the following pages.



**ATTENTION:**

always comply with the notifications and instructions on the plates applied to the machine and operate exclusively based on the instructions provided in this handbook (for example those reported in Paragraph 3.8 – General Warnings and Behaviour Norms).

### 3.3.1. Lifting and Transportation

#### 3.3.1.1. Residual Risks During Lifting and Transport Phases

During the lifting and transport phases, risks are present related to:

- ▶ operations on the machine by staff that is unqualified, untrained, uninformed or not correctly equipped.
- ▶ wrong choice or wrong use of transport and movement vehicles (for example, forklift or hoist) for the machine;
- ▶ crushing of operators responsible for movement;
- ▶ loss of load stability during the operations in question;
- ▶ projection of mobile parts of the machine that cannot be adequately removed or fastened;
- ▶ knocking of parts or machine components with people or property due to sudden movements of the machine or incorrect behaviour of the employees conducting the operation;
- ▶ knocking or falling of machine components, damaging the machine and the relative protections;
- ▶ possible unhealthy or excessively forced movements by transport and movement operators of the machine components.

#### 3.3.1.2. Necessary Individual Protection Devices



#### 3.3.1.3. Attention Warnings During Lifting and Transport Phases

During the lifting and transport phases, it is necessary to follow the attention warnings in this paragraph.

- ▶ Only appoint specialist and trained staff for these operations for machinery movement operations that are capable of choosing and using the lifting and transport vehicles in a safe manner most appropriate for the situation (for example a crane or hoist).
- ▶ Check and, if necessary, ensure that all the parts capable of moving are correctly fastened (or, if planned, removed and reassembled when the operation is complete).
- ▶ Do not lift, for any reason, the various parts of the machine by grabbing them by non-structural elements (for example, cables or sheaths).
- ▶ Ensure there are no people near the zone where the lifting, movement and unloading operations take place and always keep a safe distance.
- ▶ Always give warning of the start of manoeuvres.
- ▶ Do not transit under suspended loads.
- ▶ Do not carry anyone on the loads.

### 3.3.2. Installation and Connection

#### 3.3.2.1. Risks During Installation and Connection Phases

During the installation and connection phases, risks are present related to:

- ▶ operations on the machine by staff that is unqualified, untrained, uninformed or not correctly equipped.
- ▶ contact with electrically powered elements;
- ▶ knocking or crushing by moved machine components;
- ▶ tripping or falling over electrical power connections;
- ▶ machine damage during the installation and connection phases.

#### 3.3.2.2. Necessary Individual Protection Devices



#### 3.3.2.3. Signs Present

The machine is supplied with specific danger and forbidden signs; see Paragraph 3.4 – Safety Signs.

#### 3.3.2.4. Attention Warnings During Installation and Connection Phases

During the installation and connection phases, it is necessary to follow the attention warnings in this paragraph.

- ▶ Follow the instructions relating to safety reported in Paragraph 3.3.1 – Lifting and Transport during the necessary movement operations of the machine components.
- ▶ Use the auxiliary equipment and, however, any other machinery or equipment (electrical or pneumatic) only having understood the instructions reported in the relative Use and Maintenance Handbook or after specific and formal training.
- ▶ Choose an installation location which:
  - includes sufficient space for normal use and maintenance of the machine,
  - enables the correct connections necessary for machine functioning,

- In relation to electrical energy, the earthing system connection must be connected **before any other connection** to the electrical mains line.
- Protect connection tubing to energy sources using adequate rigid sheathing or cable passages.
- Conduct the intervention requested using standardised work tools (ladders, various tools) and pay maximum attention to elements that could cause tripping or cause cuts and trauma.
- The operational settings of the machine cannot be dealt with until the machine is inspected: the presence of possible assembly or installation errors could in fact lead to serious accidents for the operators responsible for the operations.
- Before proceeding with the inspection and the first functioning of the machine, check its parts do not present any physical damage due to knocks, tears or abrasion and that all the connections present were correctly conducted, with no possibility of disconnection.

### 3.3.3. Machine use

#### 3.3.3.1. Residual Risks during Machine Use Phase

During machine use the following risks are present due to:

- use of the machine by staff that is unqualified, untrained, uninformed or not correctly equipped.
- contact with electrically powered parts;

#### 3.3.3.2. Necessary Individual Protection Devices



#### 3.3.3.3. Signs Present

The machine is supplied with specific danger and forbidden signs; see *Paragraph 3. 4 – Safety Signs*.

#### 3.3.3.4. Attention warnings during machine use

During use of the machine, it is necessary to follow the attention warnings in this paragraph.

- Only use the machine if all the safety protection devices are intact.
  - Do not remove, for any reason, the safety devices and protections installed.
- Comply with all the safety and danger signs affixed to the machine.
- Ensure all the safety and danger signs affixed to the machine are legible.
  - Wear all the IPD necessary, regularly checking their integrity (immediately signal any IDP that are no longer capable of conducting the specific task they were assigned for).
  - Do not intervene on the machine without having fully and carefully read this handbook.
  - Use the auxiliary equipment and, however, any other machinery or equipment (electrical or pneumatic) only having understood the instructions reported in the relative Use and Maintenance Handbook or after specific and formal training.
  - Immediately signal functioning anomaly situations.
  - Do not conduct any intervention (including cleaning) on movement units or hot surfaces.
  - Do not conduct unpermitted operations on the machine (refer to the instructions reported in this handbook).
  - Do not use the machine when under the influence of medicine or beverages that can slow your reflexes.

### 3.3.4. Maintenance and Demolition

#### 3.3.4.1. Risks During Maintenance and Demolition Phases

During the maintenance and demolition phases, risks are present related to:

- operations on the machine by staff that is unqualified, untrained, uninformed or not correctly equipped.
- contact with powered electrical parts;
- knocking or crushing by moved machine components;
- contact with hot elements on the machine or relative equipment;
- contact with the refrigerant.

#### 3.3.4.2. Necessary Individual Protection Devices



#### 3.3.4.3. Signs Present

The machine is supplied with specific danger and forbidden signs; see *Paragraph 3. 4 – Safety Signs*.

#### 3.3.4.4. Attention warnings during maintenance and demolition Phases

During the maintenance and demolition phases, it is necessary to follow the attention warnings in this paragraph.







- Conduct the interventions requested using the standardised work tools (ladders, various tools) and always wearing the necessary IPD.
- The implementation of maintenance and demolition interventions must be performed by qualified, specifically trained staff.
- Check that the power supplies are adequately sectioned and that nobody can reactivate them prior to concluding the requested interventions (use of locks, adequate signs and consolidated work procedures); also check that any residual energy was discharged before conducting the intervention.

- Operate, as much as possible, on the machine and the tubing only after emptying it and before proceeding to restarting, guaranteeing adequate cleaning of the system.
- Obtain the necessary work permits and check all the preparation procedures of the machine for maintenance operations are correctly conducted.
- Use the auxiliary equipment and, however, any other machinery or equipment (electrical or pneumatic) only having understood the instructions reported in the relative Use and Maintenance Handbook or after specific and formal training.
- Do not use, for any reason, petrol, solvents or inflammable fluids to clean parts, but use commercial, approved detergent that is inflammable and non-toxic.
- Do not make changes, transformations or applications to the machine that could prejudice safety, without having obtained written authorisation from the manufacturer.
- Before restarting the machine, check that all the safety devices of the machine were restored.

### 3.4. Safety signs

Signaling labels are present on the machine, which are indicated in Table 4.

Table 4 – Description of the signaling labels present on the machine.

	LABEL	DESCRIPTION
A		This label indicates that it is forbidden to remove the safety devices and protections installed on the machine; it is usually accompanied by the explicatory writing: DO NOT REMOVE THE PROTECTION DEVICES.
B		This label indicates that it is forbidden to perform any intervention (including lubrication and cleaning) in proximity of moving parts; it is usually accompanied by the explicatory writing: DON NOT REPAIR OR REGULATE DURING MOTION.
C		This label warns about the danger due to the presence of mobile parts in proximity of the area in which the machine is positioned.
D		This label warns about the danger due to the presence of warm surfaces in proximity of the area in which the machine is positioned.
E		This label warns about the danger due to the presence of elements under voltage in proximity of the area in which the machine is positioned.
F		This label warns about the obligation to read the manual for the installation

G		Warning to the sharp parts durino condenser cleaning
---	---	--

### 3.5. Work Area and Position of the Operator

The machine functions automatically requesting the intervention of the operator corresponding to the control and command software only to manually start and stop and for functioning programming. The operator's work area therefore exclusively corresponds to the control panel on the machine.

### 3.6. Noise and Vibration Indications

#### 3.6.1. Noise

BLOCKSYSTEM P - SF - SV were designed and manufactured to reduce the noise emitted during normal functioning to a minimum.

The level of mass acoustic pressure A generated by BLOCKSYSTEM P - SF - SV and measured, following the criteria set by the norms in force, during functioning is less than 70 dB (A).

#### 3.6.2. Vibrations

In use conditions in compliance with the instructions supplied by the manufacturer in this handbook, the vibrations were not such to create dangerous situations.

The operator however, if vibrations occur, should immediately stop the machine and signal the phenomenon to the manufacturer's support service.

### 3.7. Proper and Improper Use of the Machine

The machine was designed and manufactured **exclusively** for industrial and commercial refrigeration in stable locations. Blocksystem P and SV were exclusively designed to be installed on vertical walls. Blocksystem SF was designed exclusively to be installed on horizontal walls (ceiling).

The MACHINE can **exclusively** use the refrigerating gas for which it was designed (typically R404A). As an optional the manufacturer can create machine models capable of using other refrigerating gas (for example R134a). Assess what is reported on the label of the machine to identify the refrigerating gas for which the machine was designed and manufactured.

The machine **was designed and manufactured to work in environments free of a potentially explosive atmosphere and as such cannot generate a potentially dangerous atmosphere.**

The machine must be adequately protected from the weather elements

It is good safety practice to place powder extinguishers near the machine. To prevent the possibility of fire, it is necessary to keep the machine clean of pieces of plastic, oil, solvents, paper and rags.

The use of the machine for different operations could cause damage to persons or the machine itself and is therefore considered **improper use** for which the manufacturer cannot be held responsible.



**WARNING:** *in case of a different destination of use, it is indispensable to consult the Manufacturer's Technical Office in advance.*

### 3.8. General Warnings and Behavioural Norms

To avoid any risky conditions to people or damage to the machine, we recommend you scrupulously follow the general warnings and behavioural norms reported here.



**DANGER:** *the manufacturer declines all responsibility for any damage to property and/or persons deriving from improper interventions conducted by unqualified, untrained or unauthorised staff.*

➤ The operators responsible for machine management must be adequately trained to use it at its best and without risk and must operate in a comfortable environment that guarantees the best safety and hygiene conditions possible.



**DANGER:** *prevent the machine being used by unauthorised staff or untrained staff without supervision: in fact, before starting work, each operator must be perfectly aware of the position and functioning of all the controls and features of the machine. Furthermore, the operator must have read this handbook ENTIRELY.*

➤ Before using the machine, ensure that any dangerous conditions to safety are adequately eliminated and that there are no operators present in the danger zones near the machine.

➤ Before using the machine, ensure all the guards are in place and that all safety devices are present and efficient.

➤ Warn supervisors of any functioning irregularities in the machine or any problems relating to the integrity of the machine protections.

➤ Carefully read the machine labels. Do not cover them for any reason and replace them immediately if damaged.

➤ Do not rest liquid containers on the machine.

➤ Consult this handbook on the safety specifications in force and the specific IPD to implement for personal safety; in particular, however, the staff responsible for the machine must wear suitable clothing, by avoiding or paying due attention to:

loose clothing,  
wide sleeves,  
ties or hanging scarves,  
necklaces, bracelets and rings.

- ▶ Staff responsible for maintenance of the machine must be aware of all the procedures reported in *Chapter 6 – Maintenance and Demolition* and be adequately prepared technically to correctly interpret the instructions and diagrams in this handbook and to intervene on the machine.
- ▶ The area where the maintenance operations take place must always be clean, dry and with suitable equipment always available and efficient.
- ▶ The work area must never be occupied in such a manner to interfere with the free movement of the operator. In case of emergency, immediate access to the machine must be guaranteed for responsible staff.
- ▶ In the aforementioned area, access to people who are not directly responsible for machine functioning is forbidden, to avoid danger due to distraction or negligence during machine intervention.
- ▶ If intervention has to be conducted near the electrical components, work with dry hands and use dielectric gloves (working on electrical components with wet hands leads to almost certain danger of electrical shock).



**DANGER:**

*you should ensure that before starting any type of machine intervention or corresponding to its components or accessory equipment to section power; if this is not possible, it is necessary to take measures to allow you to operate on the machine in safe conditions.*



**DANGER:**

*tampering or unauthorised replacement or one or more parts of the machine and use of accessories, tools or consumable materials other than those indicated by the manufacturer can generate danger of injury.*



**ATTENTION:**

*all the materials with environmental impact which must be eliminated after interventions or processes on the machine must be disposed of according to norms in force. If necessary, entrust specialist structures to dispose of them.*

### 3.9. Machine Data and Technical features

#### 3.9.1. Identification Plate

To identify the machine, a CE identification plate is affixed to it; the identification data reported on this plate must be notified to the manufacturer's offices on each request for intervention or to order spare parts. Specifically, the identification plate reports the following data:

- code,
- registration,
- ampere absorption (A),
- Watt absorption (W),
- refrigerant type,
- power voltage (Volt/Ph/Hz),
- maximum operating pressure PS HP (high pressure side) – PS LP (low pressure side),
- maximum operating temperature TS HP (high pressure side) – TS LP (low pressure side),
- overall class according to directive 97/23/ CE (PED).

**Registration Identification**

- figure 1 and 2 = last two figures of year of manufacture,
- figure 3 and 4 = week of year in which the machine was manufactured,
- figures 5, 6, 7 and 8 = progressive number.

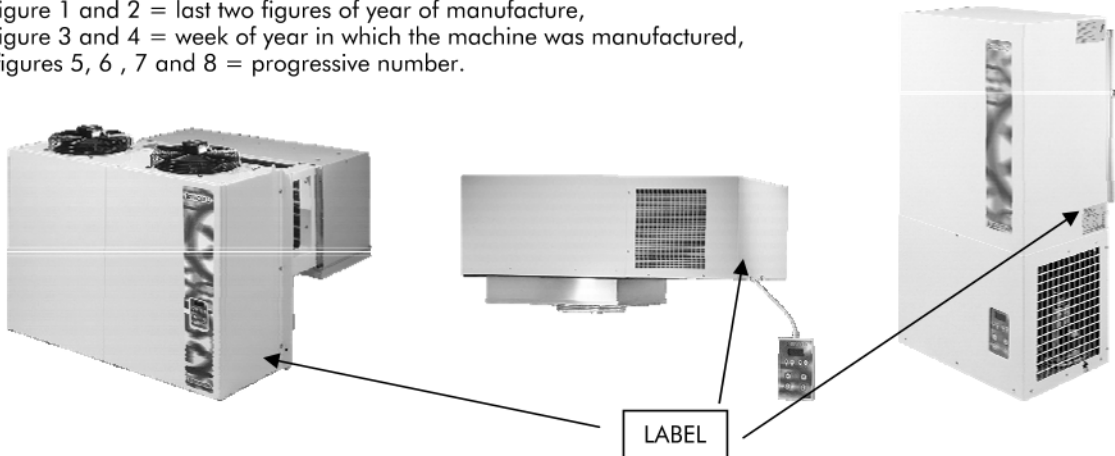

### 3.10. Technical Data and Overall Dimensions

The technical features of the machine are found in *Chapter 9 – Attachments* in this handbook.

## 4. Transport and Installation

### 4.1. General information

The installation and possible re-installation of the machine must be conducted directly by **qualified staff**.

Before proceeding to installing the machine, it is necessary to prepare the power supplies and utilities necessary for the correct functioning of the system, following the indications reported in this chapter and, if necessary, consulting the **manufacturer's** Technical Office in advance.



**ATTENTION:**

*This product as sold complies with the 97/23CE (PED) standard and is marked with the relevant category. After purchase it is the responsibility of the owner to ensure that this equipment is regularly maintained continue its compliance up to the stage when it is finally decommissioned according to the relevant national law.*



**DANGER:**

*the manufacturer declines all responsibility for any damage to property and/or persons deriving from improper interventions conducted by unqualified, untrained or unauthorised staff.*

#### 4.1.1. Power and Utilities

The power supplies and utilities necessary (responsibility of the purchaser) for machine functioning exclusively consist in the supply of electrical energy.

Unless otherwise indicated, the **purchaser is responsible for:**

- the preparation of transport vehicles to transport the machine to the assembly or installation location;
- the preparation of equipment necessary for assembly and installation;
- the preparation of the installation location;
- the preparation of auxiliary vehicles and consumable materials (for example, non-flammable and non-corrosive detergents, materials and tools necessary for cleaning and cover).

### 4.2. Transportation and Movement

The indications contained in this paragraph must be complied with during the transport and movement phases of the machine, which can occur in the following situations:

- machine storage;
- assembly and first installation of the machine;
- de-installation and dismantling of the machine;
- moving and relocating the machine.



**DANGER:**

*the manufacturer declines all responsibility for any damage to property and/or persons deriving from improper interventions conducted by unqualified, untrained or unauthorised staff.*

To conduct the task in question, the following Individual Protection Devices are necessary:



During transport or movement of the machine, it is necessary to follow the warnings below:

- Check the lifting equipment is suitable for the weight and dimensions of the machine.
- Do not bang the structure or guards of the machine with equipment or otherwise.

#### 4.2.1. Lifting



**DANGER:**

*lifting operations must be conducted with the direct supervision of a qualified mechanical maintenance person or a manufacturer technician.*

Lifting to move and subsequently position the machine can be performed using any adequate vehicle that guarantees its lifting in a safe and efficient manner (for example a hoist using a harness system for the machine). See *Figure 2*.

Figure 2 – Lifting the machine.

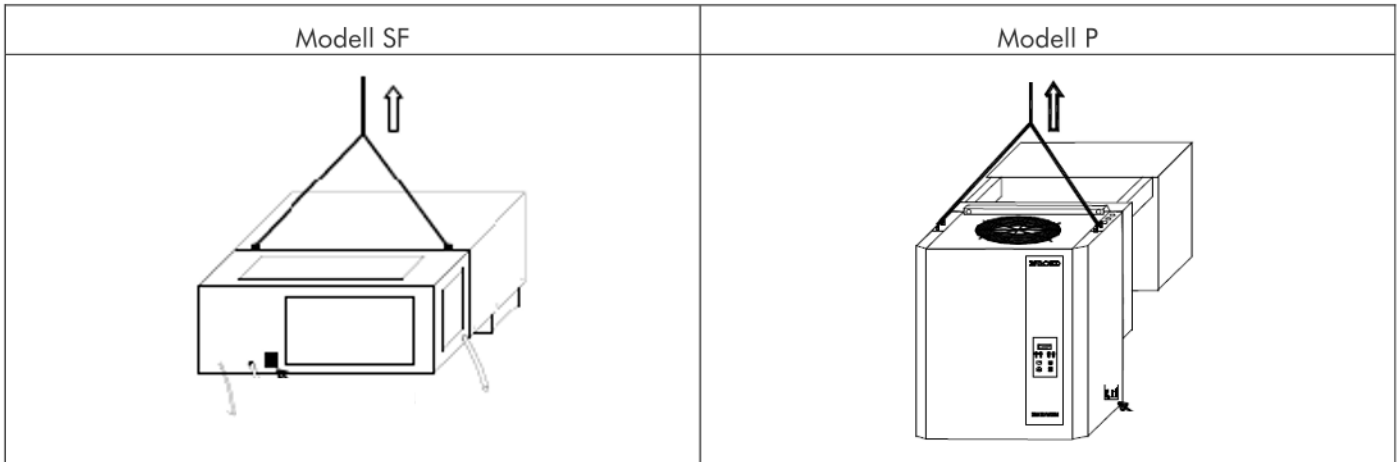

To correctly perform the lifting operations, follow the warnings reported below.

- Never use two lifting vehicles simultaneously.
- Never stay under suspended loads.
- If using steel ropes, always apply the end eye to the lifting hook.
- If using steel ropes, pay attention not to create sharp bends, i.e. with a bending radius lower than that of the rope end eyelets.
- Use adequately wide ropes, to enable the angle between the ropes and the horizon to always be over 45°.

### 4.2.2. Machine movement

For reduced distances, as in the case of transport to the assembly or storage locations of the machine, it is necessary to use lifting equipment (for example, forklift and hoists) suitable for the dimensions and weight of the machine.



**ATTENTION:** during all these operations follow the precautions necessary to avoid knocking and tipping over, moving the machine in a manner not to loose balance.



**DANGER:** ensure there are no unauthorised staff near the zone where the lifting, movement and unloading operations take place and always keep a safe distance.

### 4.3. Installation



**DANGER:** the manufacturer declines all responsibility for any damage to property and/or persons deriving from improper interventions conducted by unqualified, untrained or unauthorised staff.

To conduct the task in question, the following Individual Protection Devices are necessary:



The Blocksystem P – SV **must** be installed in locations where good recycling and exchange of air is guaranteed and **must** only be installed on vertical walls. The Blocksystem SF **must** be installed in locations where good recycling and exchange of air is guaranteed and **must** only be installed on horizontal walls (ceiling). For other installations, we recommend you contact the manufacturer. For positioning of a mono-condensing unit and the evaporator, comply with the minimum heights reported in Figure 3

Figure 3 – Minimum compliance heights.

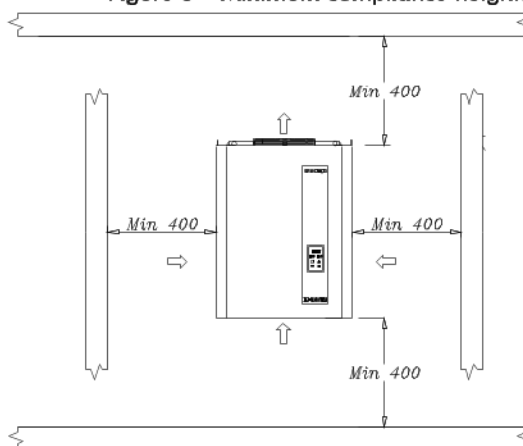

During installation, leave the machine sufficient space to conduct maintenance in safe conditions. For correct functioning of the machine, we recommend the following minimum thicknesses of the coldroom walls (polyurethane insulation): MBP and HBP coldroom insulation thickness **60 mm**; LBP coldroom insulation thickness **100 mm**.

### 4.3.1. SF Series Installation Method

To proceed to installation of the machine, implement the following procedure:

1. On the ceiling of the coldroom, based on the model, make a hole of suitable dimensions as indicated in the pages from *Figure 13 to Figure 17 of Chapter 9 at the end of the handbook*.
2. Position the anti-condensate slab supplied along the perimeter of the hole.
3. Lift the machine with the hoist or another suitable vehicle in compliance with the lifting instructions in *Figure 2*.
1. Position the machine in the hole made in the ceiling of the coldroom and place the evaporating part in from outside.
5. Fasten the machine to the ceiling of the coldroom with self-threading screws using the two brackets and the screws supplied (*Figure 4*).
6. Seal the perimeter of the aluminium conveyor with silicon (suitable for use in the coldroom) to avoid infiltration of warm air inside the coldroom.

**Figure 4 – Machine positioning in coldroom.**

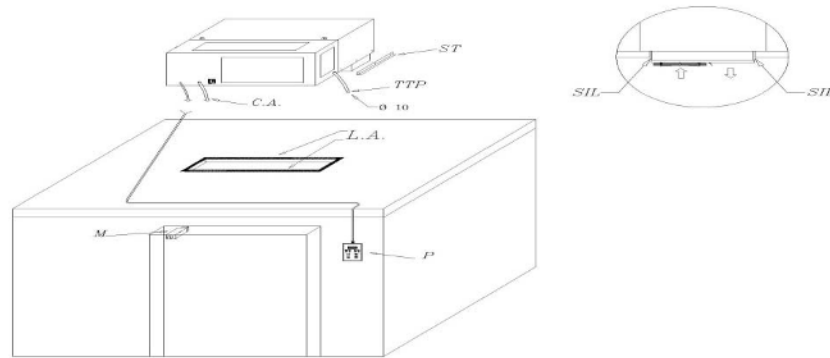

Legenda / Legend / Legende / Legende / Leyenda	
TTP	= Tubo di troppo pieno / Overflow water tube / Tuyau de trop plein / Abflußrohr / Rebosadero
ST	= Staffa di fissaggio / Fixing bracket / Etrier de serrage / Spannbügel / Grapas De Fijacion
CA	= Cavo alimentazione / Mains cable / Cable d'alimentation / Netzkabel / Cable De Alimentacion
M	= Micro-porta / Door micro-switch / Détecteur de porte / Tür-Kontakt Schalter / Micro-interruptor
LA	= Lastra anticondensa / Anticondensing plate / Plaques anticondensation / Kondens-Gegen Platte / Cinta anticondensacion
P	= Pannello di comando / Control panel / Panneau de controle / Steuerungs-Paneel / Panel de mando
SIL	= Silicone / Silicon / Silicón / Sylicon / Silicona



**ATTENTION:** *the machine is equipped with a condensate water evaporation tank. We recommend you connect a rubber tube to the overflow tube to enable evacuation of water in case of functioning or use anomalies.*

### 4.3.2. P Series Plug-In Version Installation Method

To proceed to installation of the machine, use the following procedure:

1. On the wall of the coldroom, based on the model, make a hole of suitable dimensions as indicated in the pages from *Figure 8 to Figure 12 of Chapter 9 at the end of the handbook*.
2. Lift the machine with the hoist or another suitable vehicle in compliance with the lifting instructions in *Figure 2*.
3. Position the machine in the hole made in the wall of the coldroom and place the evaporating part in from outside.
4. Fasten the machine to the wall of the coldroom using the specific screws supplied.
5. Seal the perimeter of the plug-in with silicon (suitable for use in the coldroom) to avoid infiltration of warm air inside the coldroom. On the upper side, perform the operation before positioning.



**ATTENTION:** *if the machine has a condensate water evaporation tank, we recommend you connect a rubber tube to the overflow tube to enable evacuation of water in case of functioning or use anomalies.*



**ATTENTION:** *if the machine is not equipped with a condensate water evaporation tank, lengthen the drainage tube outside the coldroom by using a siphon*

Models PTM300 / PTM370 / PTL350 / PTL450 have two support legs supplied. For assembly positioning, see *Figure 12*.



Figure 5 – Machine positioning in coldroom.

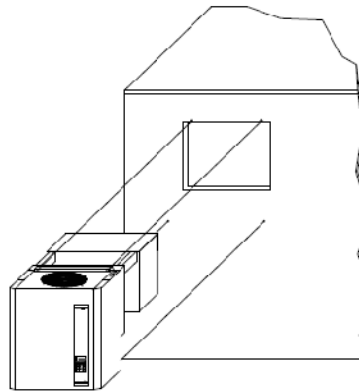

### 4.3.3. P Series Saddle Version Installation Method

To proceed to installation of the machine, use the following procedure:

1. Before assembly on the coldroom ceiling, make 2 grooves on the upper ends of the wall and a hole for water drainage, as indicated in the pages in Figure 9 at chapter 9 at the end of handbook
2. Lift the machine with the hoist or another suitable vehicle in compliance with the lifting instructions in Figure 2.
3. Position the machine on the grooves made on the wall of the coldroom.
4. Fasten the machine to the wall of the coldroom using the specific screws supplied.
5. Seal the perimeter of the grooves with silicon (suitable for use in the coldroom) to avoid infiltration of warm air inside the coldroom (Figure 6).
6. Remove the front panel of the machine. Insert the defrosting water drainage tube supplied, in the evaporator tank tube making it pass through the hole made on the wall of the coldroom (Figure 6). Then, from the other end, bring the water evaporation tank in, creating a siphon on the end part.

Figure 6 – Machine assemble saddle version.

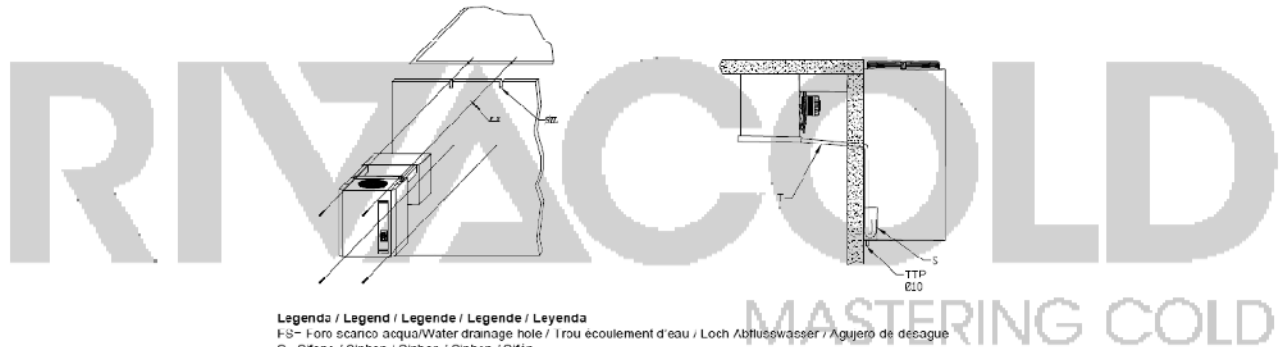

**Legenda / Legend / Legende / Legende / Leyenda**  
 F-S= Foro scarico acqua/Water drainage hole / Trou écoulement d'eau / Loch Abfluswasser / Agujero de desagüe  
 S= Sifone / Siphon / Siphon / Siphon / Sifón  
 T= Tubo scarico acqua / Water overflow pipe / Tuyau écoulement d'eau / Abflußrohr / Tubo de desagüe  
 TTP= Tubo di troppo pieno / Overflow water tube / Tuyau de trop plein / Abflußrohr / Rebozadero  
 SIL= Silicone / Silicon / Silicone / Sylticon / Silicona

Having connected the tubes, check the perfect functioning of the water drain.



**ATTENTION:** *if the machine has a condensate water evaporation tank, we recommend you connect a rubber tube to the overflow tube to enable evacuation of water in case of functioning or use anomalies.*



**ATTENTION:** *if the machine is not equipped with a condensate water evaporation tank, lengthen the drainage tube outside the coldroom by using a siphon.*

### 4.3.4. SV Series Installation Method

To proceed to installation of the machine, use the following procedure:

1. Make a hole on the walls of the coldroom of suitable dimensions as indicated in the pages of Figure 18 and Figure 19 of Chapter 9 at the end of the handbook.
2. Position the anti-condensate slab supplied along the perimeter of the hole.
3. Lift the machine with a hoist or with another suitable vehicle.
4. Position the machine in the hole made in the wall of the coldroom and place the evaporating part in from outside.
5. Fasten the machine to the wall of the coldroom with self-threading screws using the two brackets and the screws supplied.
6. Seal the perimeter of the aluminium conveyor with silicon (suitable for use in the coldroom) to avoid infiltration of cold air inside the coldroom.



**ATTENTION:** *the machine is equipped with a condensate water evaporation tank. We recommend you connect a rubber tube to the overflow tube to enable evacuation of water in case of functioning or use anomalies.*

### 4.3.5. Connection to electrical power mains

The electrical power supply (also in terms of voltage and frequency) supplied by the purchaser must be sufficient to correctly power the machine. Specifically the following instructions must be followed:

- ▶ The power cable must be laid out (no rolling or overlapping) in a position not exposed to possible knocks or tampering. It must not be near liquids, water or heat sources and must not be damaged (if so, replace it using qualified staff).
- ▶ Prepare a thermo-magnetic differential switch between the power line and the machine --- and ensure the voltage of the line corresponds to the voltage indicated on the plate (see label applied to the machine); tolerance permitted  $\pm 10\%$  of nominal voltage.



**ATTENTION:** *the thermo-magnetic differential switch must be placed in the immediate vicinity of the machine to ensure it is well visible and reachable by the technician in case of maintenance.*

- ▶ It is necessary for the section of the power cable to be adequate to the power absorbed by the machine.



**ATTENTION:** *It is compulsory, pursuant to law, to connect the machine to an efficient earthing system. All responsibilities are declined for non-compliance with this directive; all responsibility is declined if the electrical system used for connection is not implemented according to laws in force.*

- ▶ Fasten the micro-door supplied on the door jamb of the coldroom which automatically causes, on opening, the lights in the coldroom to switch on and the compressor and fans to stop in the evaporator and condenser.



**ATTENTION:** *the micro-door cable must pass far from the cables with electrical power to avoid signal disturbances.*

- ▶ Fasten the light and connect the coldroom light cable following the instructions reported inside the support.
- ▶ With the LBP range units (-15°C/-25°C) a cable is supplied for connection of the door tolerance. This connection must be conducted using a fuse dimensioned based on the tolerance of the door used.



**ATTENTION:** *do not connect the COLDROOM LIGHT and DOOR TOLERANCE cables to the 230 Volt line. The plates attached to each cable indicate the connection to perform. The maximum power of the lighting unit which can be connected to the coldroom light cable (supplied) is 100W for incandescent lights and 66W for neon lights (230V-50Hz power). The maximum power of the tolerance which can be connected to the door tolerance cable (supplied on all the LBP models) is 300W (230V-50Hz power).*

### 4.4. Storage

If necessary to store the machine for a period before installation (or following de-installation), we recommend you protect it adequately and store it in a suitable environment, with the following features:

- ▶ external surfaces resistant to atmospheric agents;
- ▶ protected against access to unauthorised people;
- ▶ with the following environmental conditions:
  - good ventilation;
  - room temperature between -20 °C and +50 °C;
  - relative humidity of compressed air 30% and 80%;
  - possibly in dry, dust-free atmosphere.



**ATTENTION:** *do not remove any packaging possibly present for certain components of the machine and take adequate precautions to protect the exposed parts.*

#### 4.4.1. De-installation

If the machine must be de-installed, proceed following the inverse order for installation reported in Paragraph 4.3 - Installation.



**DANGER:** *the manufacturer declines all responsibility for any damage to property and/or persons deriving from improper interventions conducted by unqualified, untrained or unauthorised staff.*

To conduct the task in question, the following Individual Protection Devices are necessary:



## 5. Machine use

### 5.1. Machine use



**DANGER:** *for the machine, only operators correctly training and informed on the risks present can intervene on the machine and only having fully read this use and maintenance handbook. the manufacturer declines all responsibility for any damage to property and/or persons deriving from improper interventions conducted by unqualified, untrained or unauthorised staff.*

To use the machine, the following Individual Protection Devices are necessary:



### 5.1.1. Operation

Before starting the machine, it is necessary to ensure:

- ▶ the locking screws are tight;
- ▶ the electrical connections were correctly installed;
- ▶ the coldroom door is closed to ensure the micro-door contact is closed.

### 5.1.2. Switch on/off

To switch on (off) the machine, it is necessary to press the "ON/OFF" key for 5 seconds placed on the control panel.



**ATTENTION:** when the machine is powered, the control panel display shows the writing OFF alternated with the temperature of the coldroom.

### 5.1.3. Parameter variation procedure

Functioning of the Blocksystem series SF, series P and series SV is regulated by the parameters set in the memory of the electronic central unit by the manufacturer (see Table 6). We recommend you do not change these values unless strictly necessary and in any case always contact the enabled staff. As well as for functioning, the parameters are sub-divided by safety/accessibility level:

- ▶ level 0 SETPOINT parameters direct access (see Paragraph 5.1.3.1);
- ▶ level 1 frequent use parameters access without password (see Paragraph 5.1.3.2).

The parameters can be changed on the keyboard, via the LAN (Master/Slave) network or using the Supervision network.

#### 5.1.3.1. Coldroom temperature regulation

The fields of the temperature values for which the Blocksystem series SF, series P and series SV can operate are reported in Table 5.

Table 5 – Temperature value fields.

	Minimum	Maximum
High temperature HBP (Not planned for SV)	+2	+10
Medium temperature MBP	- 5	+ 5
Low temperature LBP	- 25	- 15

It is possible to access the regulation set point of the temperature in a direct manner to display or change the value. In relation to this, implement the following procedure:

1. Press and release SETPOINT: the display shows "SET" (if there are alarms ongoing the procedure is slightly different; see Paragraph 5.1.4)
2. Press SETPOINT: in this way the green SET led switches on and the display shows the SETPOINT value.
3. Press UP and DOWN to set the new value.
4. Press SETPOINT or ON/OFF (or wait for the 5 second timeout) to confirm the value; in this way the SET led switches off and the display shows "SET".
5. Press ON/OFF (or wait for the 5 second timeout) to return to normal view.

#### 5.1.3.2. Change level 1 parameters

To change the parameters corresponding to level 1, use the following procedure:

1. press SET for 5 seconds until the display shows "reg" (regulation parameters);
2. press UP and DOWN to display the desired menu on the display;
3. press SET to access the menu; in this way the code appears of the first parameter of the menu selected;
4. press UP and DOWN to display the desired parameter;
5. press SET to display the parameter value;
6. press UP and DOWN to set the desired value;
7. press SET to confirm the value and return to the parameters list; or press ON/OFF to confirm the value and return to menu list;
8. to pass to the parameters list to the menu list press ON/OFF;
9. to exit the change parameters procedure press ON/OFF again.

If you don't press one of the keys for more than 15 seconds, the possible value display is stored in the relative parameter and you are forced to exit the change parameters procedure.

### 5.1.4. Machine status view

To view the machine status, use the following procedure:

1. press and release SET: the display shows "SET" or "AAL" if alarms are ongoing;
2. press UP and DOWN to view the relevant status. The statuses could be:
  - AAL alarms ongoing (if present)
  - SET setpoint
  - Pbl coldroom temperature probe value

- Pb2 evaporator temperature probe value
  - Pb3 probe value 3 (if present)
  - Out relay outputs status
  - InP digital inputs status
3. press SET to display the value;
  4. in the case of alarms status, outputs status, inputs status, press UP and DOWN to scroll respectively the ongoing alarms, the outputs and the inputs;
  5. press SET or ON/OFF (or wait for the 5 second timeout) to return to the list of statuses;
  6. press ON/OFF (or wait for the 5 second timeout) to return to normal view.

**Table 6 – Machine parameters.**

Code	Level	Descr.	Range	Unit	MBP	LBP	HBP (non per SV)
		List of <b>-PPS</b> passwords					
PPA		Parameters access password Entering a pre-set password will give access to protected parameters	0 ... 255		-	-	-
		List of <b>-rEG</b> adjustment parameters					
SEt	0	Setpoint	LSE ...HSE	°C [°F]	2	-18	5
diF	1	Differential temperature > setpoint + diff. -> adjustment On temperature ≤ setpoint -> adjustment Off	0.1 ... 50.0	°C [°F]	2	2	2
		List of <b>-Pro</b> probe parameters					
CA1	1	Probe 1 calibration	-20.0 ... 20.0	°C [°F]	0	0	0
CA2	1	Probe 2 calibration			0	0	0
CA3	1	Probe 3 calibration			0	0	0
		The value assigned to this parameter is added to (positive value) or taken away from (negative value) the temperature detected by the probe					
		List of <b>-CPr</b> compressor parameters					
Ont	1	Compressor ON time in the event of probe failure	0 ... 60	min	15	15	15
OFt	1	Compressor OFF time in the event of probe failure	0 ... 60	min	15	15	15
		In the event of an adjustment probe error, the compressor is enabled in cyclical mode with set operation and off times. In particular: Ont=0: the compressor remains off Ont>0 and OFt=0: the compressor remains on					
dOn	1	Compressor activation delay The time, starting from the switch on request, after which the compressor is effectively activated. In the event of network control in sequential mode, this represents the activation delay from compressor to compressor	0 ... 250	sec	0	0	0
dOF	1	Minimum compressor OFF time The time, starting from the moment of deactivation, for which it is not possible to restart the compressor	0 ... 60	min	3	3	3
dbi	1	Delay between switch on times The time, starting from the moment of previous activation, for which the compressor cannot be restarted.	0 ... 60	min	0	0	0
OdO	1	Outputs delay at power-on (compressor, fans, defrosting) This is used to delay the enabling of adjustments after the instrument has been switched on for a set amount of time. The transition from stand-by to machine activated (ON command from the keyboard) bypasses this delay	0 ... 60	min	3	3	3
		List of <b>-dEF</b> defrosting parameters					
dtY*	1	Defrosting type 0 = heating element: ends at temperature or after maximum safe time (timeout) 1 = <b>hot gas</b> : ends at temperature or after maximum safe time (timeout) For defrosting using a heating element, there is a 1 second delay between the compressor switching off and the defrosting relay being triggered	0,1		1	1	0
dit	1	Defrosting interval The maximum time (from start to start) between two consecutive defrosting cycles. When this time expires, a defrosting cycle is enabled (cyclical defrosting). The timer is reset at each defrosting request (even if not cyclical). 0 = cyclical defrosting disabled	0 ... 250	h	6	6	6

Code	Level	Descr.	Range	Unit	MBP	LBP	HBP (non per SV)	
dct	1	Defrosting interval count mode 0 = counts if the compressor is operating 1 = counts all the time	0,1		1	1	1	
dOH	1	Defrosting start delay at power-on The time, as from when the instrument is switched on, for which any defrosting requests are frozen (manual defrosting excluded)	0 ... 250	min	0	0	0	
dEt*	1	Defrosting timeout When the set time expires, defrosting is in any case ended, even if the defrost end temperature has not been reached, passing on to the drip phase	1 ... 250	min	15	15	15	
dSt*	1	Defrost end temperature The probe 2 temperature above which defrosting is ended. If, at the start of a defrosting cycle, the temperature is greater than that set, no defrosting will be carried out. In the event of a probe 2 malfunction, the defrosting cycle will in any case terminate after reaching a time limit	-50.0 ... 199.0	°C [°F]	10	15	10	
dS2	1	Defrost end temperature for the second evaporator The probe 3 temperature above which defrosting for the second evaporator is ended. If, at the start of a defrosting cycle, the temperature is greater than that set, no defrosting will be carried out. In the event of a probe 3 malfunction, the defrosting cycle will in any case terminate after reaching a time limit. <b>This function is only enabled if P01=3o4, Co4=3 and CP0=2</b> (alarm relay used for second evaporator defrosting and probe 3 used to detect the temperature of the second evaporator). In this case, the dripping phase will begin after the defrosting cycles of both evaporators have ended.	-50.0 ... 199.0	°C [°F]	10	10	10	
dPO	1	Defrosting at power-on 0 = disabled 1 = defrosting when the instrument is switched on	0,1	flag	0	0	0	
List of <b>-FAn</b> fan parameters								
FSt	1	Fans switch on temperature	probe2 ≥ FSt: fans off Fot ≤ probe2 < (FSt – FAd): fans on probe2 < (Fot – FAd): fans off	-50.0 ... 199.0	°C [°F]	8	-5	50
Fot	1	Fans switch off temperature		-50.0 ... 199.0	°C [°F]	-50	-50	-50
FAd	1	Fans switch on and off differential		1.0 ... 90.0	°C [°F]	2	2	2
Fdt	1	Post-dripping time The time after the dripping phase, during which the fans remain switched off	0 ... 60	min	1	2	0	
dt	1	Dripping time The time after a defrosting cycle during which the compressor and the evaporator are stopped in order to favour evaporator dripping	0 ... 60	min	2	2	0	
dFd	1	Fans deactivated during defrosting 0 = fans activated (operation set from FPt) 1 = fans deactivated	0,1	flag	1	1	0	
FCO	1	Fans activated with compressor off 0 = fans deactivated 1 = fans activated (operation set from FPt) 2 = fans in duty cycle operation	0 ... 2		0	0	0	
Fon	1	Fans ON time during duty cycle operation (FCO=2)	1 ... 60	min	15	15	15	
FoF	1	Fans OFF time during duty cycle operation (FCO=2)	1 ... 60	min	15	15	15	
List of <b>-ALr</b> alarm parameters								
AFd	1	Temperature alarm threshold differential This sets the re-entry temperature threshold after a high- or low-temperature alarm condition	1.0 ... 90.0	°C [°F]	2	2	2	
HAL	1	Maximum alarm threshold Above this value (absolute or referred to the setpoint) an alarm is triggered If the reference is relative, the unmarked value is added to the setpoint	-50.0 ... 199.0	°C [°F]	10	10	10	
LAL	1	Minimum alarm threshold Below this value (absolute or referred to the setpoint) an alarm is triggered If the reference is relative, the unmarked value is subtracted from the setpoint	-50.0 ... 199.0	°C [°F]	-10	-10	-10	
PAO	1	Temperature alarm delay at power-on	0 ... 10	h	4	4	4	

Code	Level	Descr.	Range	Unit	MBP	LBP	HBP (non per SV)
dAO	1	Temperature alarm delay after defrost The time, starting from the end of the dripping phase, during which no alarm is signalled. In the event of contemporaneous network defrosting, the time refers to the defrosting end command	0 ... 999	min	60	60	60
OAO	1	Temperature alarm delay after door closure The time, after the door is closed again and during which no alarm is signalled	0 ... 10	h	0	0	0
dAt	1	Defrosting alarm timeout enabling This enables the signalling of any defrosting end due to the maximum time limit being reached (timeout). 0 = signal disabled 1 = signal enabled	0,1	flag	0	0	0
List of <b>-diS</b> display parameters							
ndt	1	Decimal point display 0 = display without decimal point 1 = display with decimal point.	0,1	flag	1	1	1
ddl	1	Display during the defrosting phase 0 = normal display (as set from the ddd par.) 1 = freezes the temperature value displayed at the start of defrosting until the end of defrosting and the reaching of the setpoint 2 = "dF" until the end of defrosting and the reaching of the setpoint <b>The ddl parameter can be controlled only if the standard display (ddd par.) includes the adjustment probe (probe 1 or network probe)</b>	0,1,2		0	0	0
Ldd	1	Defrosting display block timeout The time, starting from the end of defrosting (end of dripping phase), after which the normal display is in any case restored	0 ... 255	min	6	6	6
dro	1	°C or °F selection 0 = °C 1 = °F  This selection only affects temperature measurements. The values of the parameters concerning temperature maintain their current values and therefore, they must be varied manually to adapt them to the Fahrenheit scale.	0,1	flag	0	0	0
List of <b>-CnF</b> configuration parameters							
LOC (**)	1	Keyboard lock 0 = keyboards disabled 1 = main terminal keyboard enabled 2 = secondary terminal keyboard enabled 3 = keyboards enabled (the first to request a service has precedence until completion)	0 ... 3		1	1	1
rEL	1	Software release A read-only value that identifies the software version	0.0 ... 99.9		-	-	-
List of <b>-Lan(***)</b> network parameters							
dEA	1	Supervision network address (for Master only) The address to be set on each master must take into account the number of slaves present in the LAN network preceding it: "dEA" = "dEA[previous master]" + "L01[previous master]" + 1 The Supervision network address for a Slave is "dEA[master]" + "L00")	1 ... 199		1	1	1

For models PTM068Z012, PTM080Z012, PTL060Z012, PTL080Z012, PTM110Z012, PTM140Z012, PTM200Z012, PTL130Z012, PTL180Z012, PTL200Z012, PTL260Z012, PTM300Z012, PTM370Z012, PTL350Z012 and PTL450Z012 the parameters dtY, dEt and dSt have the values (**tolerance defrosting**) reported in Table 7.

table 7

Code	Livello	Descrizione	Range	Unità	MBP	LBP	HBP
dtY	1	Defrosting type 0 = <b>heating element</b> : ends at temperature or after maximum safe time (timeout) 1 = hot gas: ends at temperature or after maximum safe time (timeout) For defrosting using a heating element, there is a 1 second delay between the compressor switching off and the defrosting relay being triggered	0,1		0	0	0

	Livello	Descrizione	Range	Unità	MBP	LBP	HBP
dEt	1	Defrosting timeout ( <b>Defrosting by heater</b> ) When the set time expires, defrosting is in any case ended, even if the defrost end temperature has not been reached, passing on to the drip phase	1 ... 250	min	30	30	30
dSt	1	Defrost end temperature ( <b>Defrosting by heater</b> ) The probe 2 temperature above which defrosting is ended. If, at the start of a defrosting cycle, the temperature is greater than that set, no defrosting will be carried out. In the event of a probe 2 malfunction, the defrosting cycle will in any case terminate after reaching a time limit	-50.0 ... 199.0	°C [°F]	15	15	10



**\*ATTENTION:** To unlock the keyboard, simultaneously press "SET" and "ON/OFF" for at least 5 seconds.



**\*\*ATTENTION:** the "LAN" network parameter is only used in case of MASTER/SLAVE and TELEMAGEMENT functioning.

## 5.2. Alarm signals

In case of alarms, the board normally activates the following actions:

- the relative alarm code is signalled on the display. In particular, the display control alternates the alarm code and the temperature normally displayed;
- the alarm led switches on;
- the relay alarm is activated.

For certain alarms and signals, the led and/or the relay is not activated. By pressing any key, the relay deactivates (if active) and the led flashes, while the display alarm code continues to be displayed. The led switches on and the alarm code disappears only when the cause that generated it is found. Table 8 reports in detail the descriptions of each alarm and the actions undertaken in this respect.

Table 8 – Alarms description.

Code displayed	Description/Control	LED enable	Relay enable	Reset Mode
E1	<b>cold room probe temperature error</b> if a probe is used for adjustment, the compressor will be activated cyclically and defrosting cycles will be disabled; if a balanced network probe is enabled, adjustment will continue, bypassing the malfunctioning probe	yes	yes	automatic when the condition ceases
E2	<b>End defrostin probe g error</b> defrosting will end due to timeout	yes	yes	automatic when the condition ceases
E3	<b>3<sup>rd</sup> probe error</b> (condenser temperature) the associated controls are disabled	blink.	no	automatic when the condition ceases
	<b>3<sup>rd</sup> probe error</b> (2nd evaporator temperature) defrosting will end due to timeout	yes	yes	
	<b>heat alarm (*)</b> adjustment is disabled	yes	no	automatic when the condition ceases
	<b>HP pressure switch alarm(*)</b> adjustment is disabled	yes	no	automatic when the condition ceases
	<b>LP pressure switch alarm(*)</b> adjustment is disabled	yes	no	automatic when the condition ceases
E4	<b>repeated heat alarm</b> adjustment is disabled permanently	yes	yes	at switch on
E5	<b>repeated HP pressure switch alarm</b> adjustment is disabled permanently	yes	yes	at switch on
E6	<b>repeated LP pressure switch alarm</b> adjustment is disabled permanently	yes	yes	at switch on
LO	<b>low temperature alarm</b>	yes	yes	automatic when the condition ceases
HI	<b>high temperature alarm</b>	yes	yes	automatic when the condition ceases
EE	<b>data saving alarm</b> default parameters are loaded	yes	yes	at power-on or after the parameter has been stored to memory
Ec	<b>condenser cleaning alarm</b>	blink.	no	automatic when the condition ceases

Code displayed	Description/Control	LED enable	Relay enable	Reset Mode
Er	network alarm (**)	yes	yes	automatic when the condition ceases
Ed	defrosting timeout alarm	blink.	no	automatic at the start of the next defrost
Od	door open timeout alarm normal operation is enabled again	blink.	no	automatic when the condition ceases
nx	slave x alarm (on master only)	yes	progr.	automatic when the condition ceases
Ux	slave x not connected (on master only) the slave is not controlled	blink.	no	automatic when the condition ceases
u0	master not connected (on slave only) the slave is released from the network and operates autonomously	blink.	no	automatic when the condition ceases
dx	slave x download failed(on master only)	blink.	no	manual or automatic when the condition ceases

(\*) No writing appears on the display.

(\*\*) For network alarms, we intend the alarm control propagated by the master to all network devices, on planning, in case of activation of the alarm relay on the master.

During functioning, in particular conditions, the signals reported in Table 9 are displayed.

**Table 9 – Particular functioning conditions.**

Code displayed	Description	Notes
OFF	unit in stand-by (operation disabled)	remains until the next ON command
dF	defrosting in progress	see par. "ddl"
dFu	defrosting not performed	displayed for 2 seconds when the defrosting command is not performed because the evaporator temperature is already above the defrosting end temperature (parameter dst)
uM	master unit	at switch on, the network configuration of the unit is displayed
uSx	slave x unit	
Cn	terminal/control connection interrupted	the terminal is not receiving data from the control



**ATTENTION:** if on start-up, the terminal connection/control is not working correctly, the terminal displays "88.8" and the leds are all off.

## 6. Maintenance and Demolition

### 6.1. General Maintenance Information

To guarantee maximum reliability to the machine and avoid dangerous conditions, scrupulously comply with the instructions and warnings reported in the following pages.



**DANGER:** for safety reasons, all the maintenance operations reported in this chapter must only be conducted by qualified technicians that are specifically trained.  
The responsible technicians must also have all the tools and IDP necessary to operate safely.



**WARNING:** to always guarantee operators full efficiency and safety of the machine and prevent problems linked to deterioration of the safety measures or machine stoppages which can be taxing, it is necessary to implement efficient preventive maintenance, by planning interventions with planned intervals, with the purpose of renewing or replacing the normal wear parts and audit the general status of the mechanical and electrical components composing the machine (and its auxiliary equipment), thereby providing the instructions on possible extraordinary operations which may become necessary.

Before conducting any type of maintenance or cleaning intervention reported in this paragraph, it is necessary to section the machine from the electrical power supply; do so by removing the plug from the power socket.



**DANGER:** the manufacturer declines all responsibility for any damage to property and/or persons deriving from improper interventions conducted by unqualified, untrained, inadequately equipped or unauthorised staff.

#### 6.1.1. Safety Signs

To conduct correct maintenance and cleaning operations, it is indispensable to take into consideration the indications reported below.

- ▶ During interventions, it is necessary to signal machine intervention using specific signs (these signs are positioned in such a manner to prevent any undesired intervention on the machine).
- ▶ During the interventions **only authorised staff** can access the work area.



**ATTENTION:** the maintenance and cleaning operations must only be conducted by expert and specialist staff that have read and understood all the indications reported in this Use and Maintenance Handbook.





**DANGER:** only dismantle the parts of the machine actually necessary to conduct the specific maintenance operation. Furthermore, before re-delivering the machine to operators, it is necessary to verify its integrity and functionality.

All the materials with environmental impact which must be eliminated after maintenance interventions must be disposed of according to norms in force.



**ATTENTION::** to dispose of materials with high environmental impact, if necessary, appoint specialist structures.

In any case, to conduct all the maintenance and cleaning operations reported below on the machine, the following Individual Protection Devices are necessary:



### 6.1.2. Verification of Material Availability

With an advance of at least **60 days** from the fixed date for maintenance interventions, conduct a detailed examination of the necessary material:

1. check the material is in the warehouse,
2. if necessary, ask the manufacturer's Technical Office for the missing pieces, at least **30 days** in advance.

### 6.2. Emergency system



**DANGER::** for the machine, only operators correctly trained and informed on the risks present can intervene on the machine and only having fully read this use and maintenance **handbook**. The manufacturer declines all responsibility for any damage to property and/or persons deriving from improper interventions conducted by unqualified, untrained or unauthorised staff.



**DANGER:** before conducting any planned cleaning interventions, ensure the machine is sectioned from the power supply, and any hot surfaces have cooled.

If a functioning fault or anomaly occurs on the electronic central unit and immediate replacement is not possible, the **EMERGENCY SYSTEM** can be used to maintain the unit operational until the central unit is replaced. To use this system, having sectioned the machine, proceed as follows:

1. Remove all bridges on the L terminals and the common ones on the board relays (terminals 25-28- 33-36-38);
2. As reported in the diagram in *Figure 7*, connect a thermostat between terminal L, the NO terminals (terminals 32,37) and the NC terminal.(terminal 34) of the relays on the compressor, defrosting and fans (COMP, DEF and FAN).
3. Then make a bridge between the L terminals and the NO terminal of the ON/OFF relay (terminal 26 for power supply of the tolerance on the carter, door and drainage where present).
4. Connect the Blocksystem SF or P or SV again to the power line and set the thermostat to the desired temperature.



**DANGER:** what we've described is a temporary connection! As soon as possible contact the vendor or directly contact the manufacturer to replace the non-operating board.



**ATTENTION:** during the entire emergency phase, defrosting is excluded, therefore we recommend you reduce opening the coldroom to a minimum.

5. When installing the new central unit, restore all the connections described in points 2, 3, 4 and 5.

**Figure 7 – Emergency system.**

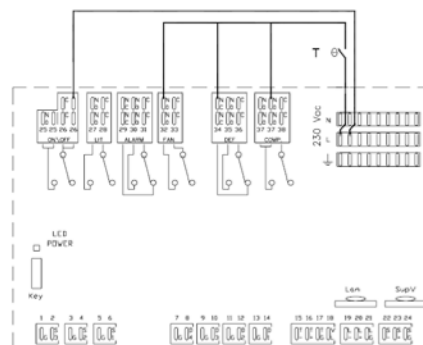

Legend:  
T = Thermostat

## 6.3. Cleaning and maintenance



**DANGER:** the manufacturer declines all responsibility for any damage to property and/or persons deriving from incorrect or incomplete maintenance.



**DANGER:** before conducting any planned ordinary maintenance interventions, ensure the machine is sectioned from the power supply; also wait for any hot surfaces to cool.



**ATTENTION:** in case of replacement of machine components, they must be replaced with identical and original components.



**ATTENTION:** Any measures taken to braze on a product category risk PED  $\geq 1$ , must be conducted by qualified professionals.

### 6.3.1. Interventions and relevant frequency

The most significant and important operations are related to ordinary maintenance and can be summarised as follows:

- ▶ On a **weekly basis** check the evaporator is clean, in particular that there is no ice accumulation. When the evaporator is obstructed by ice, conduct manual defrosting and keep the "UP" key pressed for more than 5 seconds. Repeat the procedure until the evaporator is completely clean. Check after 12 hours.
- ▶ Periodically clean (at least **each month**) the condenser by removing dust and grease. If the room where the unit is installed is very dusty, you can clean it more frequently.
- ▶ **Every four months** clean the fastened and mobile contacts, for all the counters and replace them if they show signs of deterioration.
- ▶ Check (**every four months**) the tightening of all the electrical terminals both inside the panels and on the terminal blocks of each electrical utility; carefully also check tightening of the fuse elements.
- ▶ Visually check the entire refrigerator circuit, also inside the machines, to search for refrigerant leaks, which can also be found looking for traces of lubricating oil. If in doubt, prompt, in-depth intervention is required. Check for refrigerating gas leaks:
  - for systems with  $3 \text{ kg} \leq \text{refrigerant load} < 30 \text{ kg}$  the control must be **annual**;
  - for systems with  $30 \text{ kg} = \text{refrigerant load} < 300 \text{ kg}$  the control must be **six-monthly**;
  - for systems with a **refrigerant load  $\geq 300 \text{ kg}$**  the control must be **quarterly**.
 If a leak is detected, immediate intervention is required and an audit must be conducted **within 30 days** to ensure the repair was efficient.
- ▶ **Every four months** check the regular flow of the refrigerant in the light on the liquid line.
- ▶ **Every four months** check the level of oil using the specific light (where present) on the compressor carter.
- ▶ **Every four months** use the passage light glass on the liquid line to examine the colour of the element sensitive to humidity. Green indicates dry, yellow indicates humidity. If humidity is indicated, stop the machine immediately and replace the filter on the liquid, replace the refrigerant and oil load. Repeat the control after 3 days of functioning.
- ▶ **Every four months** check the noise of the compressor. This operation should be conducted with care because it requires the system to be functioning; check the presence of ticking or vibrations which are synonymous with breakages or excessive mechanical ranges between the moving parts.

**Regularly** check the drainage of condensate water is not clogged. For the MBP and LBP models, check the water drainage tolerance is efficient.



**ATTENTION:** on completion of each maintenance and cleaning operation, reset all the fastened protections.

### 6.3.2. Interventions on safety valve (where planned)

We recommend you replace the safety valve in case it needed to intervene; during drainage, in fact, the accumulation on the seal of the valve of processing residue from components and tubing can cause the seal to become faulty.



**DANGER:** before replacing the valve, check the system, in the zone in which it is operating, is not under pressure or at a high temperature.



**DANGER:** do not dismantle the safety valve without recovering the gas in advance that is present in the liquid receiver.



**ATTENTION:** maintenance is not planned for safety valves. Removal of the cap and tampering with the seal are considered unauthorised modifications to calibration; this means the manufacturer's warranty is not valid. The inspection of safety valves is reserved for the proposed authorities and is governed by specific legal norms, in force in the country of installation.

We recommend you check the safety valve **every three years**.

## 6.4. Out of service, dismantling and demolition

To perform these dismantling and demolition operations, the following Individual Protection Devices are necessary:



### 6.4.1. Machine placed out of service

To place a machine out of service for a long period, follow the operations below:

1. Remove machine voltage.
2. Clean the machine.
3. Also conduct the maintenance operations and then cover the machine with a sheet.

### 6.4.2. Dismantling

If it is necessary to dismantle the machine, follow the procedures indicated below.

1. Isolate the machine from electrical power.
2. Refer to the *Paragraph 4.4.1 – De-installation in Chapter 4 – Transport and Installation*, proceed to de-install the machine; also contact the manufacturer's Technical Office to obtain the necessary support during this intervention.
3. To proceed to moving the machine components, work according to the instructions reported in *Paragraph 4.2 – Transport and Movement in Chapter 4 – Transport and Installation*.
4. Organise the components adequately based on the fact they have to be transported to another location (refer to *Paragraph 4.2 – Transport and Movement in Chapter 4 – Transport and Installation*), which must be stored (refer to *Paragraph 4.4 - Storage in Chapter 4 – Transport and Installation*) or demolished (refer to *Paragraph 6.2.3 - Demolition*).



**DANGER:**

*the manufacturer declines all responsibility for any damage to property and/or persons deriving from improper interventions conducted by unqualified, untrained, inadequately equipped or unauthorised staff.*

### 6.4.3. Demolition and disposal

When the machine has reached the end of its lifecycle, before proceeding to final disposal, it is necessary to perform a series of operations to minimise environmental impact linked to the disposal of the machine components, as requested by the norms in force on waste disposal.

These operations are:

1. Separate and store the parts with environmental impact, or rather:
  - a. separate the various parts that could cause pollution;
  - b. select the materials to encourage their recycling, dividing them for differentiated disposal (in particular select the plastic or rubber elements).
2. The gas contained in this system **must not** be dispersed in the environment. Thermal insulation of the buffer and oil in the compressor must undergo differentiated collection; for this reason, we recommend you dispose of the generator only in specialist collection centres and not as normal iron scrap, following the norm directives in force.
3. Dispose of the casing, or rather:
  - a. having removed and stored the polluting elements, entrust disposal of the casing to specialist structures.



**ATTENTION:**

*on demolishing the machine, ensure the identification plate of the machine and the relevant technical documentation can no longer be used.  
It is the faculty of the client to return these elements to the manufacturer's Technical Office for their destruction.  
Simple conservation in an inaccessible location of the aforementioned elements is not permitted.  
On completion of the interventions, communicate to the manufacturer's Technical Office that the machine has been disposed of.*

## 7. Optional

On the machine, on request of the client, it is possible to have the following optionals.

### R134A GAS

An alternative to the standard R404A, the machine can be designed to use different refrigerating gases, recognised by the machine code (on the CE identification plate on the machine). Y=R134a.

### WATER CONDENSATE

This is obtained by replacing the air condenser with a water condenser.

To connect the water condensers, you must use tubes with a diameter of no less than those present on the Blocksystem SF - P - SV, in compliance with the input and output instructions. If the unit is dimensioned for water condensate with tower water, the input tube is the tube composed of a joint that connects the two minor section tubes of the condenser. Instead, when condensation is planned with well water, the input tube is distinguished because a static pressure regulator valve is installed on it that is used to regulate the water flow. Install the shut-off tap of the water supply line within the operator's reach.



**ATTENTION:** *never close the water shut-off tap with the device functioning.*

To improve the yield and duration of the machine, check that:

- ▶ the temperature of the water is between 20 and 30°C for the units with tower water condensate and between 5 and 20°C for units with well water condensate;
- ▶ water pressure is between 1 and 5 bar.



**ATTENTION:** *the water tubes must be protected from low external temperatures.*

**CONDENSER FAN VELOCITY CONTROL**

**CONDENSER FANS PRESSURE SWITCH** (optional – where not standard)

Stops the condenser fan when condensation pressure goes under the calibration value less the differential.

**CONDENSER FAN VELOCITY TRANSFORMER**

Regulates the fan velocity of the condenser based on the condensation pressure, to maintain it within the limits established. It is connected to the high pressure circuit. The instructions for use are attached to the machine documentation.

**MINIMUM PRESSURE SWITCH** (optional – where not standard)

Stopping the machine, it intervenes when pressure in the suction circuit goes under the calibrated value less the differential. This occurs as the result of a fault.

**THERMOSTAT VALVE EXPANSION** (where not an optional)

If the lamination unit is the thermostat valve, the refrigeration system comes with a liquid receiver and a thermostat valve after the condenser.

**CARTER TOLERANCE**

Used to heat the compressor carter before start-up and keeping it warm during stoppage. The heat produced by the tolerance causes the evaporation of any refrigerant in liquid state which is found inside the compressor.

**REMOTE PANEL** (where not standard)

Allows positioning of the control panel at a certain distance from the machine, for example beside the door of the coldroom (maximum distance 100 m).

**VOLTAGE MONITOR**

Device that enables machine protection from low and excess voltage.

**DIFFERENTIAL THERMO-MAGNETIC SWITCH**

Device that protects the machine from surges, short circuits and indirect contacts.

**ADDITIONAL MODULE FOR MASTER/S�AVE FUNCTIONING**

Enables connection together of 2 Blocksystems SF or P or SV in a coldroom with the possibility of synchronised functions (defrosting, alarm-temperature displays and Blocksystem SF or P or SV running).

**ADDITIONAL MODULE FOR MONITORING, REGISTRATION AND TELEMAGEMENT**

Allows connection of the Blocksystem SF – P – SV to a telemagement system.

**DIFFERENT VOLTAGE**

The last digit on the abbreviation of the machine model identifies the voltage according to the following diagram:

1	230/1/50 Hz
2	400/3/50 Hz
3	110/1/60 Hz
4	220/3/60 Hz
5	220/1/60 Hz
6	460/3/60 Hz
7	380/3/60 Hz
8	230/3/50 Hz

**TELEMAGEMENT SYSTEM**

Enables monitoring and programming of the Blocksystem P-SF-SV via a PC or data recorder. It gives the possibility of advanced management (communication via modem or GSM) of all the Blocksystem SF or P or SV alarms.

## 8. Faults search

	POSSIBLE CAUSES	SOLUTIONS
A	<p><b>The compressor does not start up and does not release a humming sound</b></p> <ol style="list-style-type: none"> <li>1 Lack of voltage. Start-up relay with open contacts.</li> <li>2 Thermal protector is intervening.</li> <li>3 Loose electrical connections or wrong electrical connections.</li> </ol>	<ol style="list-style-type: none"> <li>1 Check the supply line or substitute the relay.</li> <li>2 Check the electrical connections.</li> <li>3 Tighten the connections or carry them out again in compliance to the electrical wiring diagram.</li> </ol>
B	<p><b>The compressor does not start up (but releases a humming sound) and the thermal protector intervenes</b></p> <ol style="list-style-type: none"> <li>1 Wrong electrical connections.</li> <li>2 Low voltage supply to the compressor.</li> <li>3 Faulty start-up of the condenser.</li> <li>4 The relay doesn't close.</li> <li>5 The winding on the electrical motor is interrupted or in short circuit.</li> </ol>	<ol style="list-style-type: none"> <li>1 Re-do the connections.</li> <li>2 Identify the cause and eliminate it.</li> <li>3 Identify the cause and replace the condenser.</li> <li>4 Identify the cause and substitute the relay if necessary.</li> <li>5 Substitute the compressor.</li> </ol>

	POSSIBLE CAUSES	SOLUTIONS
C	<p><b><u>The compressor starts up, but the relay doesn't open</u></b></p> <ol style="list-style-type: none"> <li>Wrong electrical connections.</li> <li>Low voltage supply to the compressor.</li> <li>Relay blocked in closure.</li> <li>Excessive discharge pressure.</li> <li>The winding on the electrical motor is interrupted or in short circuit.</li> </ol>	<ol style="list-style-type: none"> <li>Check the electrical circuit.</li> <li>Identify the cause and eliminate it.</li> <li>Identify the cause and eliminate it.</li> <li>Identify the cause and substitute the relay if necessary.</li> <li>Replace the compressor.</li> </ol>
D	<p><b><u>Intervention of the thermal protector</u></b></p> <ol style="list-style-type: none"> <li>Low voltage supply to the compressor (unbalanced phases on the tri-phase motors).</li> <li>Defective thermal protector.</li> <li>Defective electric-run condenser.</li> <li>Excessive discharge pressure.</li> <li>High suction pressure.</li> <li>Overheated compressor, hot return gas.</li> <li>Winding of the compressor motor in short circuit.</li> </ol>	<ol style="list-style-type: none"> <li>Identify the cause and eliminate it.</li> <li>Check its characteristics and replace it if necessary.</li> <li>Identify the cause and eliminate it.</li> <li>Check the ventilation and any potential restrictions or obstructions in the system circuit.</li> <li>Check the sizing of the system. Replace the condensing unit with a more powerful one, if necessary.</li> <li>Check the refrigerant load; if need be, repair the loss and add gas if necessary till the charge stated in the label.</li> <li>Replace the compressor.</li> </ol>
E	<p><b><u>The compressor starts up and circulates, the functioning cycles are of brief duration</u></b></p> <ol style="list-style-type: none"> <li>Thermal protector.</li> <li>Thermostat.</li> <li>Intervention of the high pressure switch, due to the insufficient cooling of the condenser.</li> <li>Intervention of the high pressure switch, due to the excessive load of refrigerant gas.</li> <li>Intervention of the low pressure switch, due to the scarce load of refrigerant gas.</li> <li>Intervention of the low pressure switch, due to the restriction or clogging of the expansion valve.</li> </ol>	<ol style="list-style-type: none"> <li>See previous point (thermal protector intervention).</li> <li>Small differential; correct the regulation.</li> <li>Check the correct functioning of the motor fan or clean the condenser.</li> <li>Reduce the load of refrigerant gas.</li> <li>Repair the loss and add refrigerant gas.</li> <li>Replace the expansion valve.</li> </ol>
F	<p><b><u>The compressor operates uninterruptedly or for long periods</u></b></p> <ol style="list-style-type: none"> <li>Scarce load of refrigerant gas.</li> <li>Thermostat with contacts locked in closure.</li> <li>System not sufficiently sized in function of the load.</li> <li>Excessive load to cool or insufficient insulation.</li> <li>Evaporator covered with ice.</li> <li>Restriction in the system circuit.</li> <li>Clogged condenser.</li> </ol>	<ol style="list-style-type: none"> <li>Repair the loss and add refrigerant gas till the charge stated in the label.</li> <li>Replace the thermostat.</li> <li>Replace the system with a more powerful one.</li> <li>Reduce the load and improve insulation, if possible.</li> <li>Perform defrosting till the charge stated in the label.</li> <li>Identify the resistance and eliminate it.</li> <li>Clean the condenser.</li> </ol>
G	<p><b><u>Electric-run condenser damaged, interrupted, or in short circuit</u></b></p> <ol style="list-style-type: none"> <li>Wrong electric-run condenser.</li> </ol>	<ol style="list-style-type: none"> <li>Replace the condenser with the correct type.</li> </ol>
H	<p><b><u>Start-up relay defective or burnt out</u></b></p> <ol style="list-style-type: none"> <li>Wrong relay.</li> <li>Relay mounted in the incorrect position.</li> <li>Wrong electric-run condenser.</li> </ol>	<ol style="list-style-type: none"> <li>Replace the relay with the correct one.</li> <li>Re-assemble the relay in the correct position.</li> <li>Replace the condenser with the correct type.</li> </ol>
I	<p><b><u>Cold-room temperature too high</u></b></p> <ol style="list-style-type: none"> <li>Thermostat regulated too high.</li> <li>Undersized expansion valve.</li> <li>Undersized evaporator.</li> <li>Insufficient air circulation.</li> </ol>	<ol style="list-style-type: none"> <li>Regulate it correctly.</li> <li>Replace the expansion valve with a suitable one.</li> <li>Replace it, increasing the surface of the evaporator.</li> <li>Improve air circulation,</li> </ol>
L	<p><b><u>Frosted suction piping</u></b></p> <ol style="list-style-type: none"> <li>Expansion valve with excessive passage of gas or oversized.</li> <li>Expansion valve locked in open position.</li> <li>Evaporator fan does not work.</li> <li>Gas load too high.</li> </ol>	<ol style="list-style-type: none"> <li>Adjust the valve or substitute it with a correctly sized one.</li> <li>Clean the valve of foreign substances and replace it, if necessary.</li> <li>Identify the cause and eliminate it.</li> <li>Reduce the load.</li> </ol>

# 9. Attachment

## “P” RANGE

Drawing. 8 (Plug-in version)

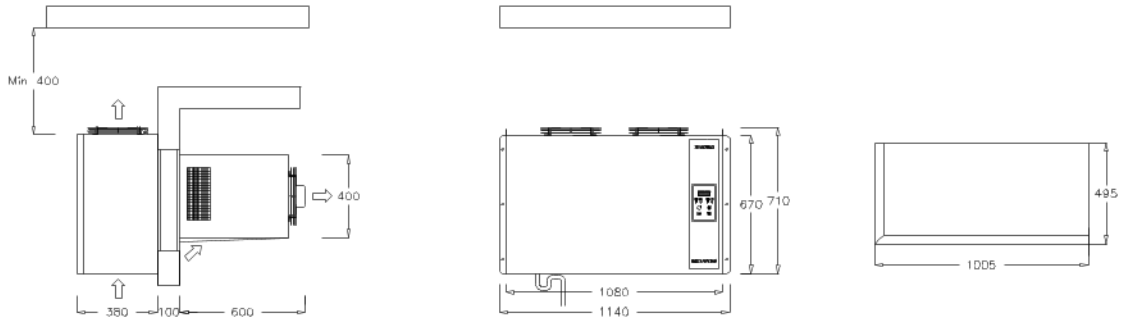

HBP		MBP		LBP		Fastening screws. Self tap. 4,8x32
Mod.	Net.Weight [Kg]	Mod.	Net.Weight [Kg]	Mod.	Net.Weight [Kg]	
PTH054_	123	PTM054_	129.5	PTL034_	141	

Drawing. 9 (Saddle version)

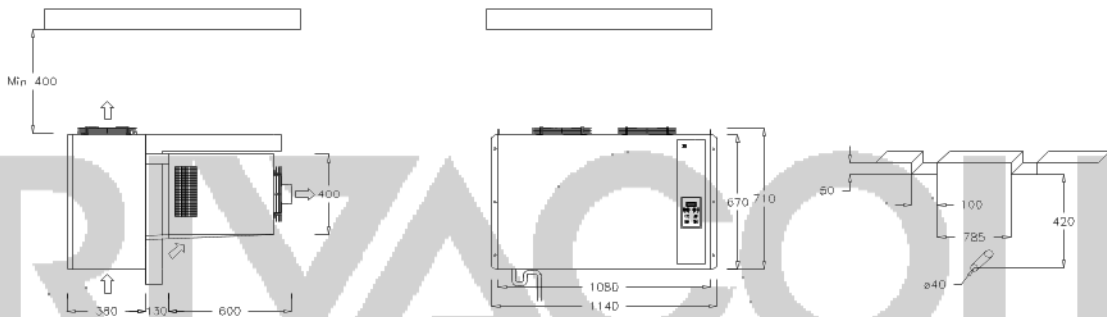

HBP		MBP		LBP		Fastening screws. self tap. 4,8x32
Mod.	Net.Weight [Kg]	Mod.	Net.Weight [Kg]	Mod.	Net.Weight [Kg]	
PAH054_	123	PAM054_	129.5	PAL034_	141	

Drawing. 10(Plug-in version)

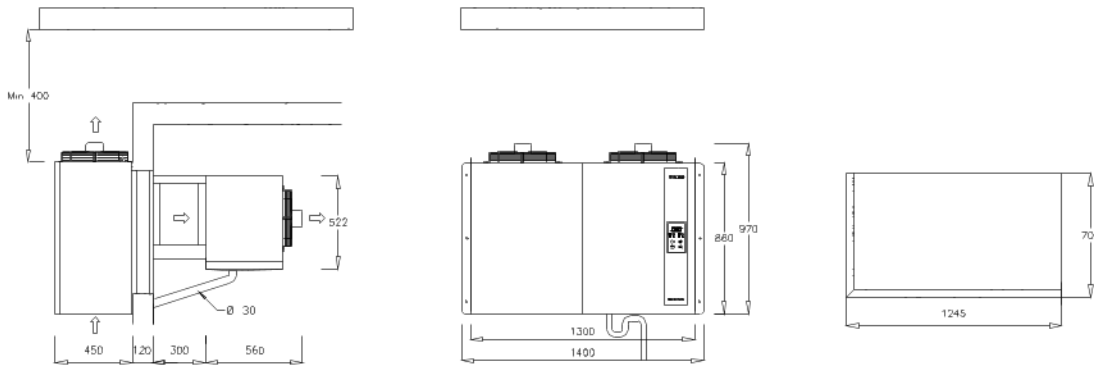

HBP/MBP		LBP		Fastening screws. M10x150
Mod.	Net.Weight [Kg]	Mod.	Net.Weight [Kg]	
PTM068_*	206.5	PTL060_*	227	
PTM080_*	222.5	PTL080_*	233	

Drawing. 11 (Plug-in version)

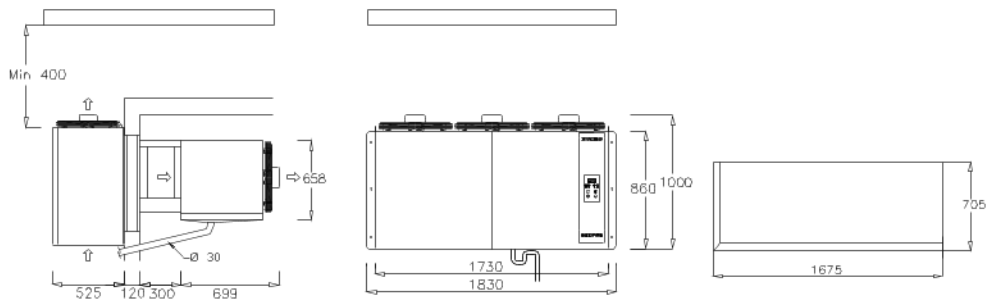

HBP/MBP		LBP		Fastening screws.
Mod.	Net.Weight [Kg]	Mod.	Net.Weight [Kg]	
PTM110_*	266	PTL130_*	329.5	M10x150
PTM140_*	290.5	PTL180_*	349.5	
PTM200_*	370.5	PTL200_*	406.5	
		PTL260_*	411	

Drawing. 12 (Plug-in version)

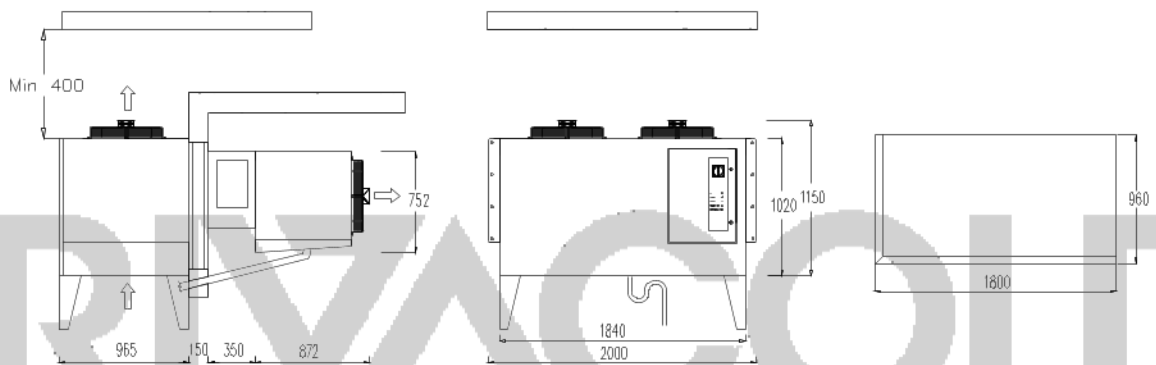

HBP/MBP		LBP		Fastening screws.
Mod.	Net.Weight [Kg]	Mod.	Net.Weight [Kg]	
PTM300_*	665	PTL350_*	771	M10x150
PTM370_*	746	PTL450_*	804	

**\*Questi modelli non sono disponibili nella versione accavallata**  
 These models are not available in the saddle version

“SF” RANGE

Drawing. 13

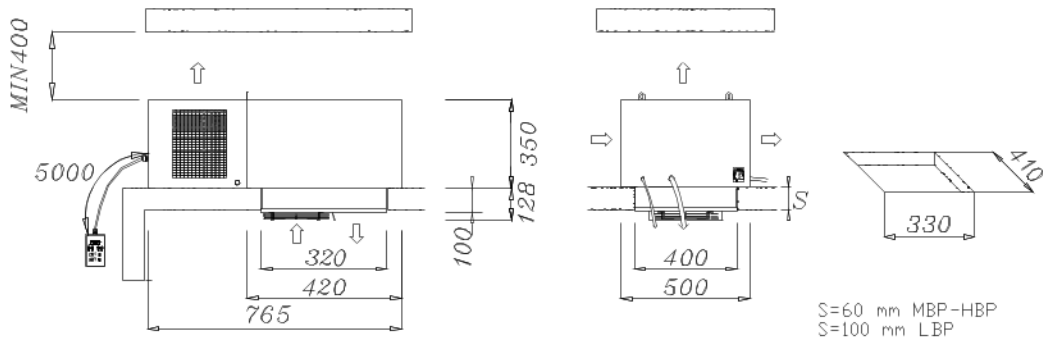

HBP		MBP		LBP		Fastening screws.
Mod.	Net.Weight [Kg]	Mod.	Net.Weight [Kg]	Mod.	Net.Weight [Kg]	
SFH003_	46.5	SFM003_	48.5	SFL003_	53.5	Self tap. 4,2x13,5

Drawing. 14

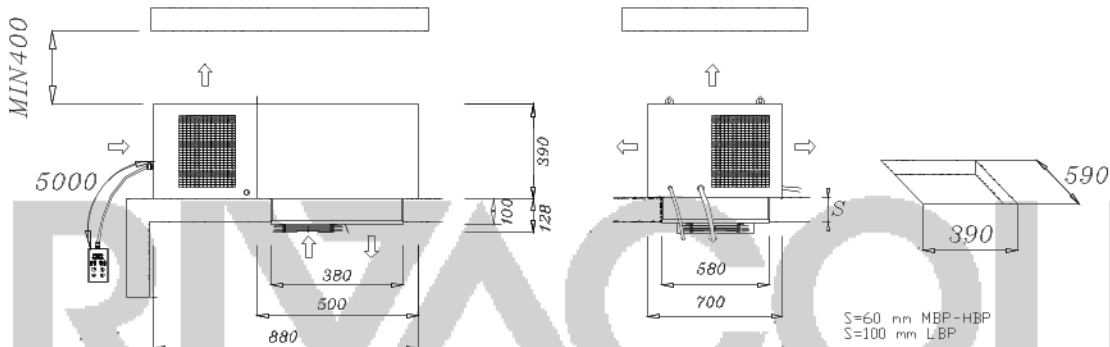

HBP		MBP		LBP		Fastening screws.
Mod.	Net.Weight [Kg]	Mod.	Net.Weight [Kg]	Mod.	Net.Weight [Kg]	
SFH006_	62	SFM006_	63	SFL006_	54	Self tap. 4,2x13,5
		SFM007_	64	SFL008_	74	

Drawing. 15

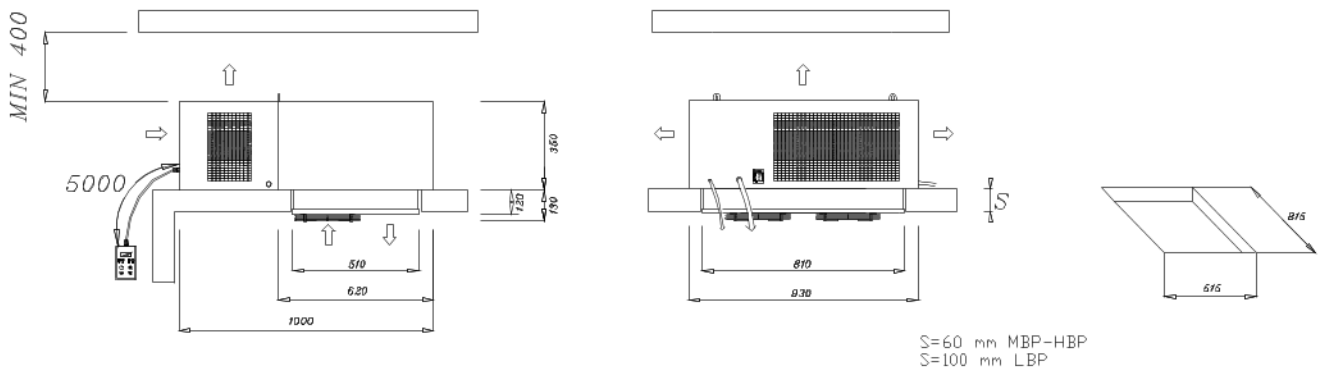

HBP		MBP		LBP		Fastening screws.
Mod.	Net.Weight [Kg]	Mod.	Net.Weight [Kg]	Mod.	Net.Weight [Kg]	
SFH009_	75	SFM009_	84	SFL009_	90	Self tap. 4,2x13,5
SFH016_	87	SFM016_	88			



Drawing. 17

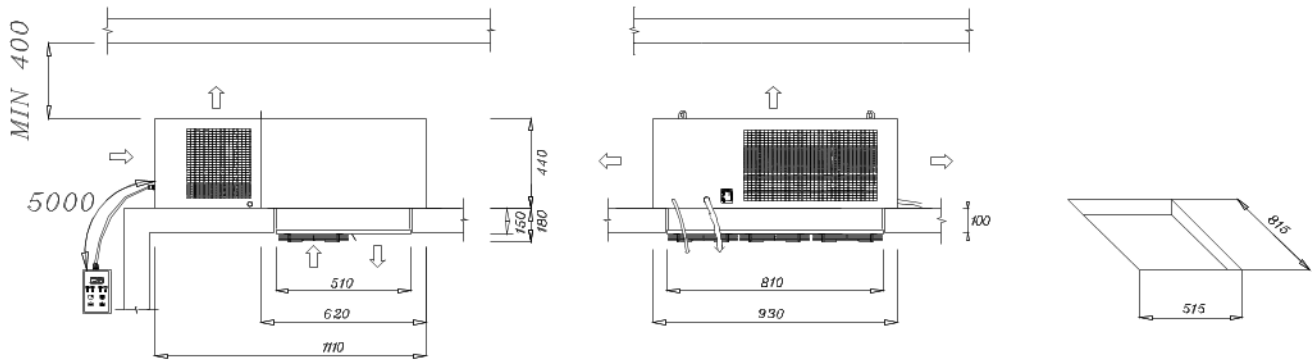

HBP		MBP		LBP		Fastening screws.
Mod.	Net.Weight [Kg]	Mod.	Net.Weight [Kg]	Mod.	Net.Weight [Kg]	
SFH022_	100	SFM022_	90	SFL012_	105.5	Self tap. 4,2x13,5
SFH034_	106	SFM034_	110	SFL016_	118.5	
				SFL020_	126	

Drawing. 17

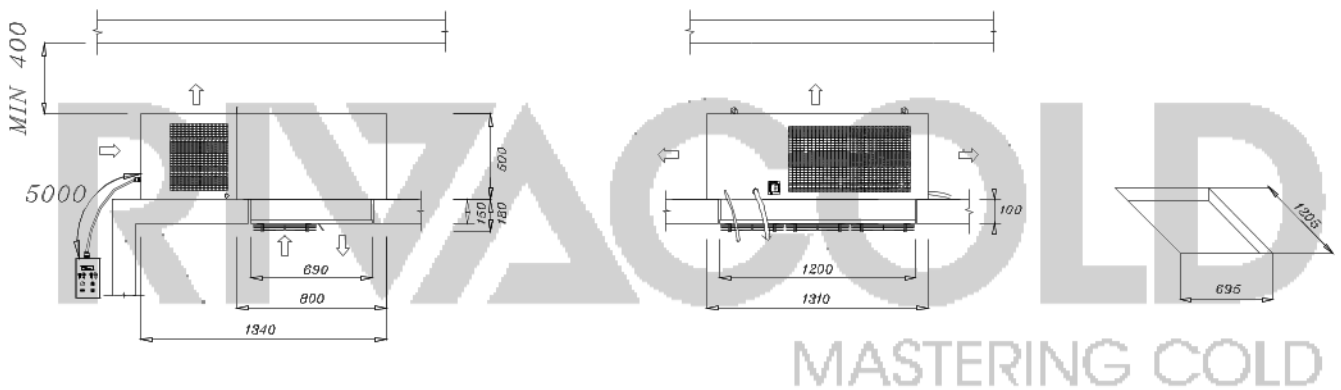

HBP		MBP		LBP		Fastening screws.
Mod.	Net.Weight [Kg]	Mod.	Net.Weight [Kg]	Mod.	Net.Weight [Kg]	
SFH054_	180	SFM054_	174.5	SFL024_	178.5	Self tap. 4,2x13,5
				SFL034_	192	

Drawing. 18

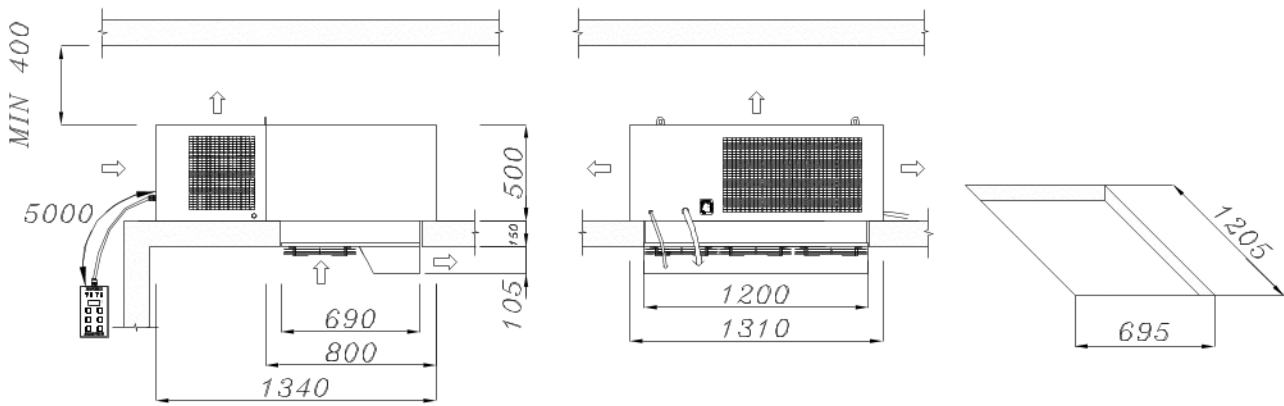

MBP		LBP		Fastening screws.
Mod.	Net.Weight [Kg]	Mod.	Net.Weight [Kg]	
SFM068_	193	SFL080_	200	Self tap. 4,2x13,5

“SV” RANGE

Drawing. 19

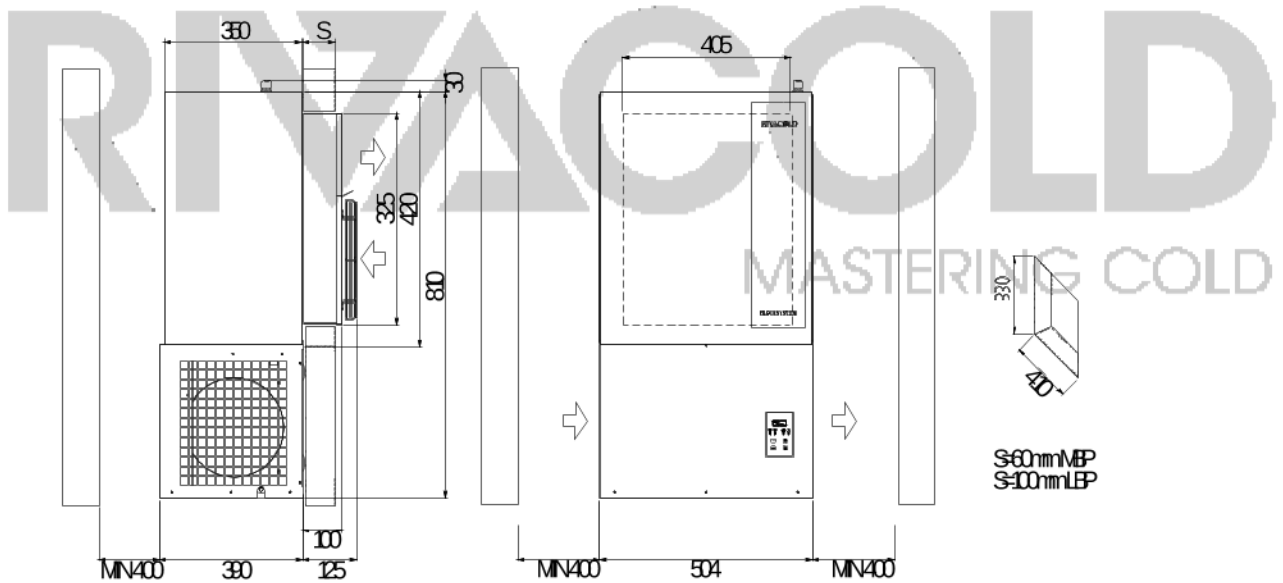

MBP		LBP		Fastening screws.
Mod.	Net.Weight [Kg]	Mod.	Net.Weight [Kg]	
SVM003_	53	SVL003_	61	Self tap. 4,2x13,5

Drawing. 20

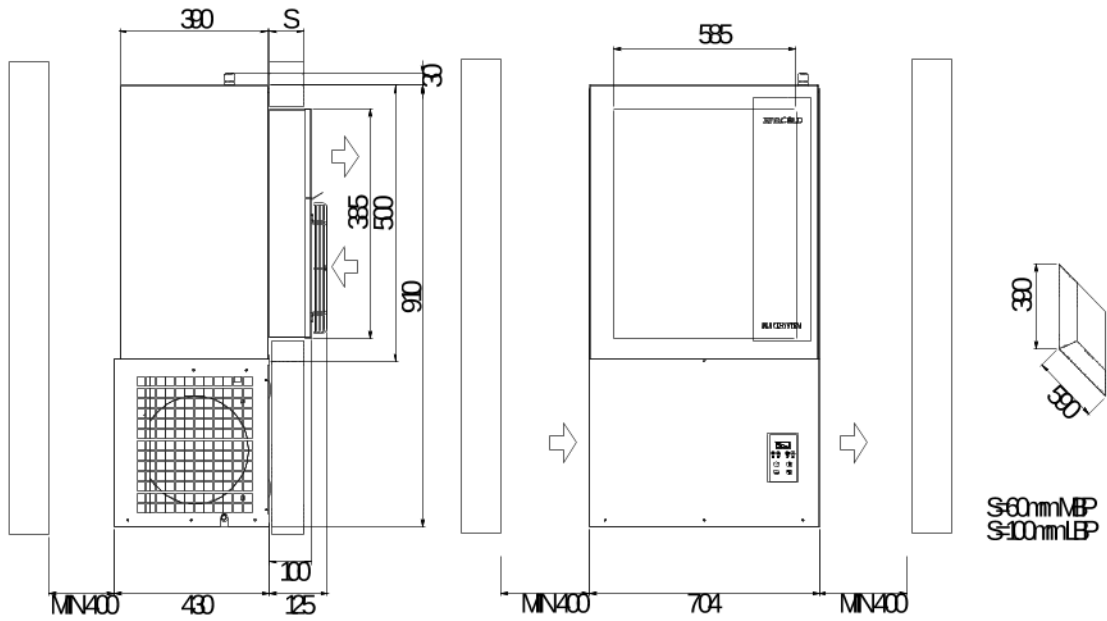

MBP		LBP		Fastening screws.
Mod.	Net.Weight [Kg]	Mod.	Net.Weight [Kg]	
SVM006_	64.5	SVL006_	67.5	Self tap. 4,2x13,5
SVM007_	65	SVL008_	79	
SVM008_	77			

**RIVACOLD**  
MASTERING COLD

**Schema frigorifero standard/Standard Refrigerating Diagram/ Schéma de réfrigération standard  
Esquema frigorífico estándar/Schemen Standardkühlschrank**

**Legenda/Legend/Légende/Legenda/Legende**

- CO= Condensatore/Condenser  
Condenseur/Condensador  
Verflüssiger
- M= Compressore/Compressor  
Compresseur/Compresor  
Verdichter
- PA= Pressostato di alta/HP pressure switch  
Pressostat haute pression/Presostato de alta  
Hochdruckschalter
- PB= Pressostato di bassa/LP pressure switch  
Pressostat basse pression/Presostato de baja  
Niederdruckschalter
- FL= Filtro deidratatore/Drier filter  
Filtre déshydratateur/Filtro deshidratador  
Trockner
- SL1= Valvola solenoide liquido/Liquid solenoid valve  
Vanne solénoïde liquide/Válvula solenoide líquido  
Magnetventil Flüssigkeit
- SL2= Valvola solenoide gas caldo/Hot gas solenoid valve  
Vanne solénoïde gaz chaud/Válvula solenoide gas calie  
Magnetventil Heißgas
- EV= Evaporatore/Evaporator  
Évaporateur/Evaporador  
Verdampfer
- VB= Valvola regolatrice di pressione  
Pressure regulating valve  
Vanne de régulation de la pression  
Válvula regulacion de pression  
Druckregelungsventil
- SR= Separatore di liquido/Liquid separator  
Séparateur de liquide / Separador de liquido  
Flüssigkeitabscheider
- RC= Resistenza carter/Crankcase heater  
Résistance carte/Resistencia cárter  
Gehäuse-Heizwiderstand
- RIC= Ricevitore di liquido/Liquid receiver  
Récepteur/Receptor de liquido  
Flüssigkeitssammler
- CA= Capillare/Capillary tube  
Tube capillaire/Capillar  
Kapillar
- VET= Valvola di espansione termostatica  
Thermostatic expansion valve  
Vanne thermostatique d'expansion  
Válvula de expansión termostática  
Thermostat-expansionsventil
- PV= Pressostato parzializzatore ventole  
Pressure switch for condenser fan control  
Pressostat pour le contrôle du motoventilateur de coi  
Presostato para regulati3n ventilator  
Druckwächter Trennung Ventilator Verflüssiger
- ASC= Tubazione per acqua di condensa  
Condensate water evaporatine pipe  
Tube d'écoulement de c'eau de condensation  
Serpentin evaporaci3n agua de condensaci3n  
Kondenswasserleitung
- VS= Valvola di sicurezza/Pressure relief valve  
Vanne de sûreté/Válvula de seguridad  
Sicherheitsventil
- IN= Indicatore di liquido/ Sight glass  
Indicateur de liquide/ Indicador de liquido  
Flüssigkeitsanzeige

**Espansione a capillare/Capillary expansion/Expansion tube capillaire  
Expansi3n por capilar/ kapillare Ausdehnung**

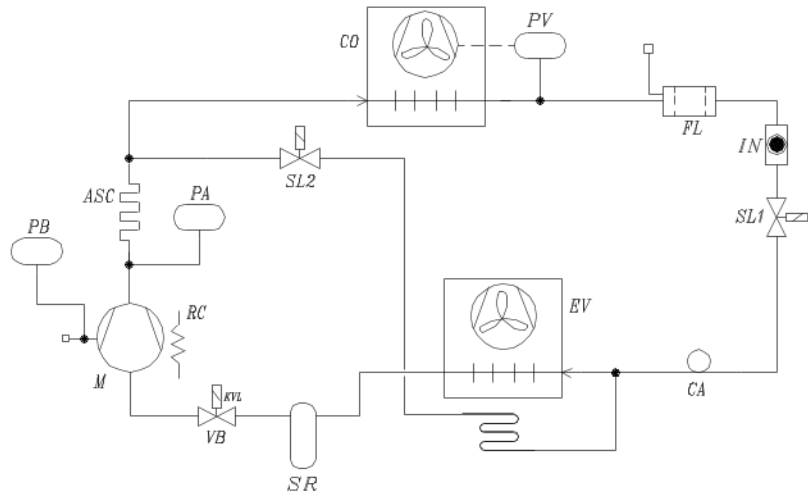

**Espansione a valvola/ Valve expansion/Expansion à vanne  
Expansi3n por válvula/ Ventilausdehnung**

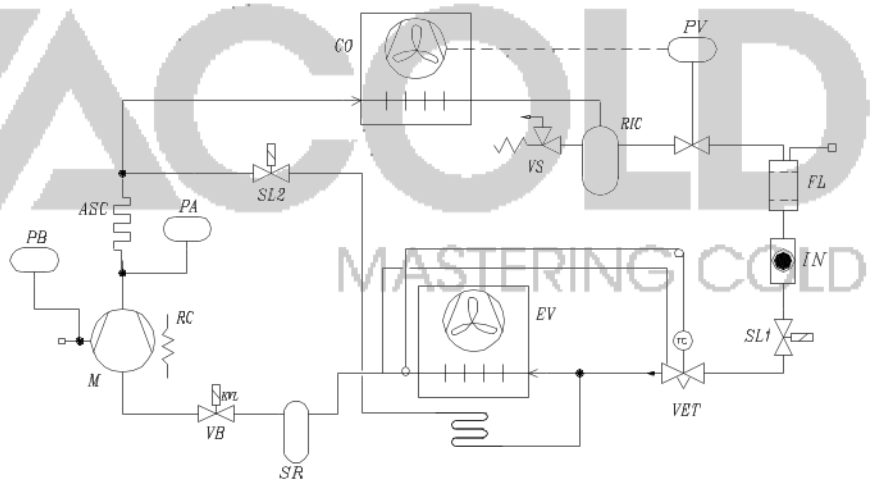

	SL1	SL2	VB	RC	PV	PB
<b>HBP</b>	--	--	--	OPTIONAL	OPTIONAL	OPTIONAL
<b>MBP</b>	•	•	--	OPTIONAL	OPTIONAL	OPTIONAL
<b>LBP</b>	•	•	•	OPTIONAL	OPTIONAL	OPTIONAL

- = di serie      -- = non previsto
- = fitted as standard      -- = not supplied
- = de série      -- = non prévu
- = de serie      -- = no previsto
- = serienmäßig      -- = nicht vorgesehen

COD. 99212054

# RIVACOLD

MASTERING COLD

**RIVACOLD S.r.l. - Costruzione Gruppi Frigoriferi e Accessori**

Via Sicilia, 7 - 61022 Fraz. Montecchio VALLEFOGLIA (PU) - Italy - Tel. +39 0721 919911- Fax +39 0721 490015

[www.rivacold.com](http://www.rivacold.com) - [info@rivacold.com](mailto:info@rivacold.com)

