

ASSEMBLY INSTRUCTIONS



SPLIT CO₂NNEXT

Company Rivacold s.r.l. - All rights reserved

These Assembly instructions are entrusted do the SPLIT CO₂Nnext system users to instruct the technicians responsible for the installation and maintenance. The instructions, drawings, tables and anything else contained in this instruction manual are of a reserved technical nature and cannot be reproduced and/or disclosed, either completely or partially, without the specific written authorisation of Rivacold s.r.l.

The installation and maintenance technicians are explicitly prohibited from disseminating the information contained and from using this manual for purposes other than for those strictly related to efficient preservation of the machine.

The company Rivacold s.r.l. cannot be held responsible or liable for damages caused by incorrect use of the documentation. In order to avoid incorrect manoeuvres that could cause danger to persons it is important to read and understand all the documentation accompanying the machine.

RIVACOLD
MASTERING COLD

Manufacturer's Name	Rivacold s.r.l.
Address	Via Sicilia, 7 Fraz. Montecchio 61022 VALLEFOGLIA (PU)
Telephone	(+39) 0721 919911
Telefax	(+39) 0721 490015

Index

1.	General information	05
1.1.	General introduction	05
1.2.	Proprietary information	05
1.3.	Contents of the assembly instructions	05
1.4.	Conventions and definitions	07
1.4.1.	Definitions	07
1.4.2.	Personal protection equipment and rules of conduct	07
1.4.3.	Graphical conventions	07
1.5.	Testing.....	08
1.6.	Warranty.....	09
1.6.1.	General conditions	09
1.6.2.	Operations that invalidate the Warranty	09
1.7.	Assistance	09
1.7.1.	Request for assistance.....	09
2.	Introduction on safety	10
2.1.	Design criteria	10
2.2.	Devices and Solutions for protection.....	11
2.2.1.	Passive safety devices.....	11
2.2.2.	Active safety devices	11
2.2.3.	Protection systems	11
2.3.	Residual risks.....	12
2.4.	Safety Plates.....	13
2.5.	Proper and improper use of the machine.....	13
2.6.	Conformity Declaration.....	13
2.7.	General Warnings and Rules of Conduct.....	14
3.	Machine Description.....	15
3.1.	Identification plate.....	18
3.1.1.	Nomenclature.....	18
3.1.2.	Technical data.....	19
3.1.3.	Noise.....	19
4.	Transport and installation.....	20
4.1.	Environmental requirements.....	20
4.2.	Power Supplies and Utilities	20
4.3.	Transport and handling.....	21
4.4.	Installation	22
4.4.1.	Cell management panel, power module and terminal block	23
4.4.2.	Wiring of the various components of the system	27
4.4.3.	Refrigerating connection	30
4.4.4.	System drain.....	33
4.4.5.	Refrigerant charge and oil	36
4.5.	Preparation for start up	38
4.6.	Cell management panel: DC Cella.....	39
4.6.1.	Display variables.....	39
4.6.2.	Symbols and icons	40
4.6.3.	First start-up	42
4.6.4.	Set point modification	42
4.6.5.	RIVACOLD pre-settings selection.....	43
4.6.6.	Pre-settings parameters	44
4.6.7.	Multifunction menu	47
4.6.8.	HACCP alarms visualization	48
4.6.9.	Inputs and outputs status visualisation	50
4.6.10.	USB Functions.....	53
4.6.11.	System information	54
4.6.12.	Access parameters modify	57
4.6.13.	Door switch function enabling	60
4.6.14.	Parameters	62

EN

4.6.15.	Main faults and alarms	82
4.6.16.	DC Cella system alarms list	84
4.7.	Storage	91
4.8.	Disassembling	92
5.	Maintenance and dismantling	93
5.1.	Maintenance and cleaning.....	93
5.1.1.	Interventions and relative periodicity	93
5.2.	Disassembly and demolition	94
5.2.1.	Disassembly	94
5.2.2.	Dismantling and disposal.....	94
6.	Troubleshooting.....	95
7.	Annexes.....	96



1. General information

1.1. General introduction

These assembly instructions are integral part of the SPLIT CO₂NNEXT product (identified, in this Document, as the machine), realized by the Company Rivacold s.r.l. For this reason, they have to be part of the technical file of the present - machine -.

These instructions have been written to provide the technicians involved in the installation and maintenance of the machine with the essential information and instructions to operate correctly and safely.



ATTENTION: Needing to be easily and immediately available, these instructions must be kept in a place that is known and accessible to everybody.



NOTE: The purchaser may request a copy of this document (for example, in case of damage of the original document) with a written request to the Manufacturer's Technical Office (see Section 1.7.1 "Request for Assistance"), engaging, in any case, to return the damaged copy.

1.2. Proprietary information

These assembly instructions contain confidential proprietary information.

All rights reserved.

These instructions may not be reproduced or photocopied, in whole or in part, without the prior written consent of the Manufacturer. Only the purchaser may use this documentary material to whom the instructions have been provided as a kit of the machine and only for the purposes of installation and maintenance of the machine to which the instructions refer.

The Manufacturer declares that the information contained in these instructions is consistent with the technical and safety specifications of the machine to which the instructions refer. The drawings, diagrams and technical data supplied are updated to the publication date of this document; they are valid exclusively for the machine to which they are enclosed.

The Manufacturer reserves the right to apply changes or improvements to this documentation without prior notification.

The Manufacturer undertakes no liability for any direct or indirect damages to people, objects or pets due to the use of this document or material of the machine in conditions other than those provided.

1.3. Contents of the assembly instructions

These assembly instructions are intended for technicians in order to be able to understand and install the machine correctly.

In fact, these instructions provide, in addition to a description of the machine, instructions and indications for:

- Proper transporting and installing of the machine;
- performing correct cleaning, adjustment and maintenance of the machine;
- drawing attention to the most important safety and accident-prevention rules.

It is necessary to carefully read all the chapters in order to understand the indications provided in these instructions and to operate with the machine; for subsequent and easier searching through the contents, refer to Table 1, containing a description of the topics addressed in the chapters.

CHAPTER	CONTENT
Chapter 1 General information	<ul style="list-style-type: none"> • Description of the assembly instructions, of their structure and of the conventions used; • definition of the terms used; • definition of the relationship between the Manufacturer and the Purchaser/User (in terms of warranty and assistance conditions).
Chapter 2 Introduction on safety	<ul style="list-style-type: none"> • Presentation of general indications on the machine, on the solutions adopted for the protection of operating personnel; • Presentation of the residual risks present
Chapter 3 Machine description	<ul style="list-style-type: none"> • Machine description • presentation of the main technical data concerning the machine.
Chapter 4 Transport and installation	<ul style="list-style-type: none"> • Description of the lifting and handling procedures; • description of the installation methods, electrical connection and commissioning of the machine; • description of machine storage procedures. • Description of the machine disassembling.
Chapter 5 Maintenance and dismantling	<ul style="list-style-type: none"> • Description of the verification and control procedures of the parts and components of the machine (in particular, of the parts most subject to wear); • description of the procedures that allow the designated personnel to clean the machine; • indications on how to perform disassembly, scrapping and dismantling of the machine.
Chapter 6 Troubleshooting	<ul style="list-style-type: none"> • List of the potential machine malfunctioning and of the relative solutions.
Chapter 7 Annexes	Indications on the: <ul style="list-style-type: none"> • Manuals of the individual partly-completed machines

Table 1 – Structure of the assembly instructions



1.4. Conventions and definitions

The assembly Instructions for the machine were divided into chapters to enable, for each life phase of the machine (transportation, installation, maintenance and decommissioning) readily available information necessary for the user of the machine.

The entire documentation relating to the machine was prepared by developing the topics indicated by the Machinery Directive (2006/42/EC), by the PED Directive (2014/68 EU) and by the current safety regulations.

The configuration of certain components or devices described or shown in the documents may differ from those fitted on the machine, which could have been designed according to specific requirements or safety regulations; in this case, some descriptions, references or best practices can have a general nature, but they are still effective.

Dimensional drawings and photographs are provided as an example as a reference for easier understanding of the text.

1.4.1. Definitions

MACHINE: It is the term used in these Assembly Instructions to indicate the SPLIT CO₂NNEXT system.

P.P.E.: It is the acronym for Personal Protective Equipment(s).

DANGEROUS ZONE: Any area within or next to the machine where the presence of an exposed person represents a risk to the safety and health of that person.

USER: Any person (entrepreneur/company) who adequately uses the machine or who entrusts its related use or operations to instructed persons.

EXPOSED PERSON: Any person wholly or partially present in a dangerous zone or near such areas.

MECHANICAL MAINTENANCE TECHNICIAN: Qualified technician allowed to work on any mechanical component, to carry out the necessary adjustments, repairs and maintenance intervention.

The mechanical maintenance operator is not permitted to carry out interventions on powered electrical plants.

ELECTRICAL MAINTENANCE TECHNICIAN: A qualified technician in charge of electrical works (adjustment, maintenance, repairs) and, when necessary, works inside powered electric cabinets and the junction boxes.

HANDLING PERSONNEL: Qualified personnel who carry out the tasks of handling the machine or the materials used if the operation requires the use of lifting devices.

MANUFACTURER'S TECHNICIAN: Qualified technician provided by the Manufacturer of the machine to perform complex interventions, in particular situations or, however, when agreed upon with the user.

1.4.2. Personal protection equipment and rules of conduct

For each of the operations described in these instructions are indicated the means of protection that personnel are required to use and the rules of conduct that allow protection of the safety of the operators themselves.

1.4.3. Graphical conventions

The graphic layout of these Assembly Instructions is such as to allow easy recognition of the contents; in this context, for example, the instructions are associated with lists, as indicated below:

- this symbol identifies a generic bullet list or a bullet list consisting of simple actions (the order in which the actions are presented is not binding, but recommended);
- 1. the actions are presented is mandatory to correctly and safely perform the intervention in question).

Italicised text is used, in particular, for:

italic text

- The cross references used in these instructions are expressed in the following way: "Paragraph/Table" with the number and, in general, the specification "of the Chapter" with the number and the relative name (when it is not specified it is implied that the paragraph or the table belong to the current chapter);
- the technical and specialised terms, the first time they appear in the text;
- foreign terms which are not commonly used (normally, the first time they appear in the text).

bold text it is used to highlight words, phrases or parts of a procedure.

Editorial pictograms

To ensure further knowledge of the machine, the text of these assembly instructions is accompanied by indications that complete them, providing additional information, highlighting tasks that require essential attention and also particularly significant hazards to consider; in this regard, the following notation is used:



DANGER: It indicates situations or operations that must be performed or information to which particular attention must be paid to prevent causing injuries to persons.



WARNING: It indicates situations or operations which may damage the machine and/or the equipment connected to it.



ENVIRONMENTAL NOTE: It indicates situations or operations in which there is the possibility of causing damage to the environment.



NOTE: it indicates the notes, warnings, suggestions and other points to which to draw the reader's attention or to complete the explanation with further information.

Personal Protective Equipment (PPE)

This paragraph indicates the graphic symbols used in these instructions to indicate the need to use certain PPE.

SYMBOL	DESCRIPTION
	It indicates the need to use suitable head protectors to perform the described operation.
	It indicates the necessity to use suitable protective gloves to perform the operation described (possibly of the dielectrics type for operations on the electrical system).
	It indicates the necessity to use suitable protective clothing to perform the operation described.
	It indicates the necessity to use suitable safety shoes to perform the operation described.
	It indicates the necessity to use protective goggles to perform the operation described.

Table 2 – Individual protection devices

1.5. Testing

The machine is directly tested by the manufacturer during the production phases at the headquarters of Rivacold s.r.l.

1.6. Warranty

1.6.1. General conditions

The Manufacturer, Rivacold s.r.l., guarantees the machine and the equipment produced by the Manufacturer itself as being free from material and processing defects for a period that is agreed upon when the contract for the sale of the same machine is concluded.

The parts subject to wear and all the tools and consumables supplied by the Manufacturer together with the machine are excluded from the warranty.

1.6.2. Operations that invalidate the Warranty

Any attempt to disassemble, modify or tamper with a component of the partly-completed machine by the user or by unauthorised personnel entails invalidating of the warranty and exempts the Manufacturer from any responsibility for any damage to persons or property. deriving from such tampering.

The Manufacturer is also deemed to be exempted from any liability with invalidation of the warranty relating to the machine in the following cases:

- not foreseen machine uses (see in this regard the Paragraph 2.5 “Proper and improper use of the machine”);
- use contrary to that required by the regulations in force in the country of use;
- installation of the machine under conditions other than those specified in Chapter 4 - Transport and Installation;
- installation not compliant with the specifications provided in Chapter 4 - Transport and Installation;
- full or partial failure to comply with the instructions provided in this instruction manual;
- non- or incorrect maintenance;
- use of spare parts which are not original or not specified by the Manufacturer.

1.7. Assistance

As regards the maximum exploitation of the services provided by the machine and the extraordinary maintenance operations, this instruction manual does not replace the experience of trained and qualified installers, users and maintenance technicians.

In this case, the Technical Assistance Service of Rivacold s.r.l. provides:

- Telephone support on the features and the simplest interventions to carry out on the MACHINE;
- Shipping of documentary material;



WARNING: If in any doubt about the correct interpretation of the instructions provided in these assembly instructions, contact the Technical Assistance Service (as indicated below) to obtain the NECESSARY clarifications.

1.7.1. Request for assistance

The Technical Assistance Service contact details are:

TECHNICAL OFFICE OF THE COMPANY RIVACOLD S.R.L.
Telephone: (+39) 0721 919911 - Telefax: (+39) 0721 490015
Via Sicilia, 7 - Fraz. Montecchio
61022 VALLEFOGLIA (PU) - ITALY

Provide the name, model and serial number of the machine when asking for assistance.

2. Introduction on safety

2.1. Design criteria

During the design phase the machine has been applied the principles and concepts consistent with the paragraphs on the harmonized standards indicated in Table 3.

STANDARD	NAME
EC Directive no. 2006/42	Machine Safety Directive
UNI EN ISO 12100: 2010	Machinery safety - Fundamental concepts, main design principles - Part 1: Main concepts, general principles for design
UNI EN ISO 12100: 2010	Machinery safety - Fundamental concepts, main design principles - Part 2: Technical principles
UNI EN ISO 13857: 2008	Safety of machinery – Safety distances to prevent hazard zones being reached by upper and lower limbs
UNI EN ISO 14120: 2015	Machinery safety – Guards - General requirements for the design and construction of fixed and mobile guards
UNI EN 378-1: 2017	Refrigeration systems and heat pumps – Safety and environmental requirements – Part 1: basic requirements, definitions, classification and selection criteria
UNI EN 378-2: 2017	Refrigeration systems and heat pumps – Safety and environmental requirements- Part 2: design, construction, testing, marking and documentation
IEC EN 60204-1: 2006	Safety of machinery - Electrical equipment of machines - Part 1: General rules

Table 3 - Main harmonized standards used in the machine design

Compliance with the relevant paragraphs of the afore-mentioned harmonised standards has made it possible to eliminate or reduce risks in the best way possible, both during normal operation and during maintenance operations.

The components used have been carefully chosen from those available on the market; the materials the machine is made of involve no risks to the health and integrity of persons. All parts supplied by third parties are CE-marked (when envisaged) and comply with the relevant directives of reference. All components have been strictly controlled in accordance with the quality standards prescribed by the current regulations.

For the machine, the necessary warning and protection measures have been adopted in relation to the residual risks (see, in this regard, Section 2.3 "Residual Risks").

2.2. Devices and Solutions for protection

For further information in this regard, see the paragraph 2.2 “Devices and Solutions for protection” of the manual CO₂NNEXT code 99215071.

2.2.1. Passive safety devices

For the machine the devices and constructive solutions described below were adopted:

- fixed guards close to the moving parts;
- external fairing with fixed access doors (if present);
- safety signalling in correspondence of the machine guards.

2.2.2. Active safety devices

For the machine, the active safety devices described below were adopted:

- maximum safety pressure switch for each automatic reset compressor (PSH) or for specific versions with safety pressure switch for each manual reset compressor (PZH);
- safety valve on the MT and LT circuit low pressure side (if present);
- safety valve(s) on the intermediate receiver;
- safety valve on the high pressure side, (if present).

The valve calibration is shown on the valves themselves and has been dimensioned on the basis of the indications of the EN 13136 standard.



ATTENTION: It is absolutely forbidden to modify the calibration of the safety pressure switch and/or to inhibit its operation.

2.2.3. Protection systems

The machine is equipped with guards to safeguard anomalous solutions acting both on the pressure circuit and on the tension circuit; For further information about the protection systems of the machine, see the individual instruction manuals attached.

RIVACOLD
MASTERING COLD

2.3. Residual risks

In order to avoid any condition of danger to persons or damage to the machine due to residual risks, or those risks that remain despite all the provisions adopted, or from potential risks that are not evident, the Manufacturer recommends that maintenance technicians and all personnel assigned to the machine strictly observe the warnings indicated on the following pages.

Furthermore, it is recommended to read and follow the warnings contained in the instruction manual of each component of the machine: air evaporator (code 99212060-99212061), condensing unit CO₂NNEXT (code 99215071) and control panel of the cold room.



ATTENTION: Always respect the warnings and the indications of the plates placed on the machine and act exclusively according to the instructions provided in this instruction manual and in the instruction manual of the individual components.



ATTENTION: All operations to be performed on the machine must be performed by qualified, trained, informed or properly equipped personnel.



Residual risk of intoxication

To avoid impacts or damage that could cause leaks of gases dangerous to human health, install the machine in a dry, protected and sufficiently ventilated place in compliance with the laws of the country of installation.



Residual risk of burns

Before carrying out any work on the machine, make sure that the hot surfaces have cooled down; wear protective gloves to avoid burns.

RIVACOLD
MASTERING COLD

2.4. Safety Plates

On the machine there are pictograms/warning plates.



WARNING: The user is responsible to keep them clearly visible and readable.

If the plates or the symbols on the machine are damaged, they have to be promptly replaced to reset their safety function;

For safety reasons, all the plates and the pictograms applied on the machine have to be kept in good conditions, cleaned and free of obstacles which may reduce their visibility. Ensure that they are always readable in every conditions, free of dust, grease or ground.

Each component has the necessary pictograms supplied by the manufacturer. It is forbidden to remove, modify or tamper with the plates and the pictograms already present on the components. However, the client can at any time add plates and pictograms to improve the system safety.

As regards their position on the machine, please refer to the instruction manuals of the individual components of the machine:

- air evaporator (code 99212060-99212061),
- condensing unit CO₂NNEXT (cod. 99215071)

2.5. Proper and improper use of the machine

The machine which is the subject of these assembly instructions has been designed and constructed **exclusively** for refrigeration. The machine is set to use **exclusively** refrigerant gas R744 (CO₂).

The manner in which each machine is designed to use only the above refrigerant is specified.

It is therefore important to use the machine in compliance with the refrigerant fluid for which it was designed and built and as received from the Manufacturer.

The machine has been designed and built to work in environments where **there is no potentially explosive atmosphere.**

The machine has to be suitably protected against weather conditions.

It is a good precautionary measure to have powder extinguishers in the vicinity of the machine. To prevent the possibility of fire, keep the machine clean of plastic pieces, oil, solvents, paper and rags.

The use of the machine for operations other than those indicated as permitted can cause harm to people or damage to the machine; such use is defined as **improper use** for which the Manufacturer undertakes no liability.



DANGER: The user MUST view the type of gas contained in the machine and its quantity in order to operate properly.



ATTENTION: In case of different use, it is essential to consult in advance with the Manufacturer's Technical Office.



DANGER: With R744 (CO₂) type refrigerant, it is necessary for all operations to be carried out only by specialized technicians trained to operate with this type of substance.

2.6. Conformity Declaration

This document is accompanied by a Conformity Declaration which will be released by the manufacturer when purchase the machine.

2.7. General Warnings and Rules of Conduct

In order to avoid any risk to persons or damage to the machine, it is advisable to strictly follow the warnings and general rules of conduct reported here.



DANGER: The Manufacturer disclaims any liability for any damage to property and/or people arising from improper operations carried out by unqualified, untrained or unauthorized staff.

- Operators in charge of operation of the machine must be adequately trained to best use it, with no risk, and must work in a comfortable environment that guarantees the best possible safety and hygiene conditions.
- Before using the machine ensure that any hazardous conditions for safety have been removed and no operators are present in the danger area near the machine itself.
- After removing the packaging, make sure all machine parts are intact, otherwise contact your dealer.
- Before using the machine, make sure all guards or other protections are fitted and that all safety devices are present and working.
- Carefully read the labels on the machine. Do not cover them for any reason and replace them in the event that they become damaged.
- Do not place liquid containers on the machine.
- Consult these instructions on the safety provisions in force and the specific PPE to implement for staff safety; in particular, the staff responsible for the machine must wear suitable clothing, avoiding or paying due attention to:
 - loose clothing,
 - wide sleeves,
 - ties or draping scarves,
 - necklaces, bracelets and rings.
- Staff responsible for maintenance of the machine must be aware of all the procedures outlined in Chapter 5 - Maintenance and Demolition and have adequate technical preparation to correctly interpret the instructions and diagrams attached to these instructions and to intervene on the machine.
- The area where the maintenance operations are carried out must be dry, clean and suitably equipped with all necessary tools.
- If it is necessary to perform interventions in the vicinity of electrical components, operate with dry hands and use dielectric gloves.
- If the machine is installed in a not easily accessible position for the operator, it is necessary to have suitable structures to allow the access to the intervention areas.



DANGER: It is necessary to ensure that before starting any type of intervention on the machine or on its components or accessory equipment, the power supply is disconnected; if this is not possible, it is necessary to provide precautions that in any case allow operating in safety close to the machine.



DANGER: The leaking of refrigerant gas following intervention of the safety valve can cause damage to property and/or to persons.



DANGER: Tampering with or unauthorised replacement of one or several parts of the machine and the use of accessories, tools and consumables other than those indicated by the Manufacturer may result in an accident.



DANGER: The R744 (CO₂) refrigerant is colourless and odourless. Its presence in the environment can cause asphyxiation. All operations must be carried out using gas presence detectors and in compliance with the safety regulations of the country of installation.



ATTENTION: With R744 (CO₂) type refrigerant, it is necessary for all operations to be carried out only by specialized technicians trained to operate with this type of substance.



ATTENTION: All materials with an environmental impact that must be eliminated as a result of interventions or work on the machine must be disposed of according to the regulations in force. If necessary, use specialist facilities for their disposal.

3. Machine description

The models of the machine in object in this document are keeled condensation units which can be used in the commercial refrigeration, air evaporators and external cell panels.

The faired condensing units are systems for positive and negative refrigeration where the heat can be disposed of into the environment.

The air evaporators are equipped with electronic fans and with a pitch-pitch thermostatic valve, with temperature probes already cabled by the manufacturer and with overheating adjusting driver, already mounted on board. The external cell panel assembled by the manufacturer provides the thermostatic valve drive management, one part to manage the air evaporator power (fans and defrosting management) and a terminal block box to allow the user an easy connection between evaporator and condensing unit CO₂NNEXT.

The connection between the devices constituting the machine is possible by means of a cable kit that the use can select among four different length provided by the manufacturer.

The faired condensing units are compact, low noise systems and suitable for working outdoors.

The air evaporator are suitable for cell application. These are equipped with electronic motorised fans EC of suction type, provided with pitch-pitch electronic thermostatic valve, temperature probes and driver EVC Ice to manage the thermostatic valve, assembled by the manufacturer together with the necessary sensors.

The system has the "UltraCap" functionality which ensures the refrigeration system safety or in the event of absence of network voltage.

The machine has been designed and optimized to work with R744 (CO₂).

The machine can communicate with the component constituting it through Modbus RTU communication through RS485.

As regards the refrigeration, electric diagrams, management and functioning logics, refer to the dedicated documentation and manuals attached to the instruction manuals of the individual machine components.

RIVACOLD
MASTERING COLD

The machine consists of condensing unit for outdoor CO₂NNEXTm, evaporator for cell and its management panel. On the right front panel of the condensing unit, there is the electric panel on which the main disconnect and the display are installed.

An example is shown below. For further information, please refer to the electric diagram and to the attached documentation to the condensing unit CO₂NNEXT code 99215071.

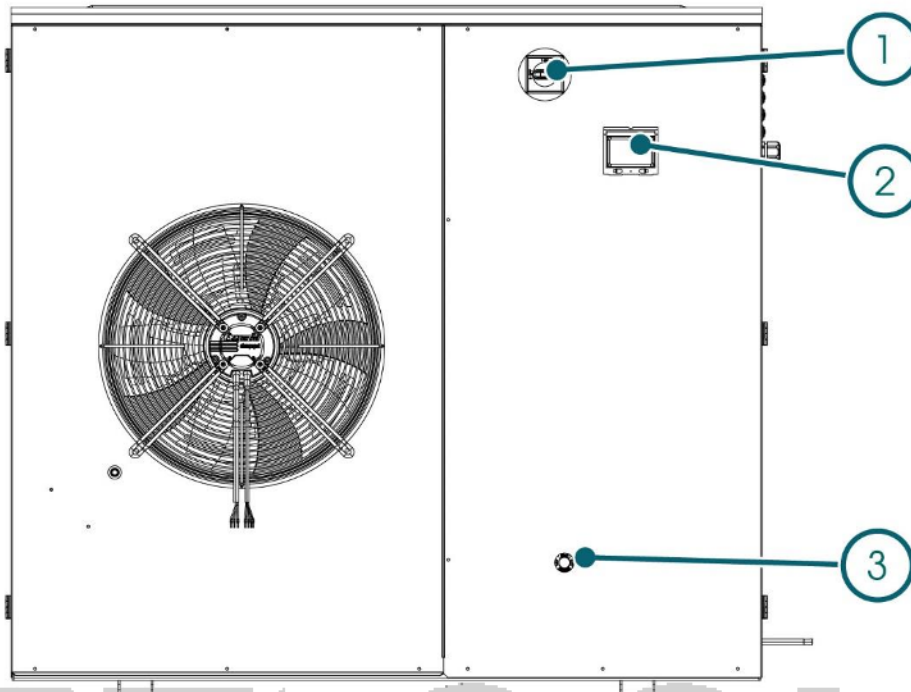

- 1. Main switch
- 2. Display*
- 3. Liquid indicator

*As regards the display description, see the attached manual of the partly-completed machine relative to the condensing unit. CO₂NNEXT cod. 99215071

The air evaporator (1) installed inside the cell, has on-board the drive to manage the proportional expansion electronic valve which is installed and cabled directly on the air evaporator together with the necessary sensors.

The cell management panel (2) is a device consisting of:

- DC Cella Control;
- Power module to manage the air evaporator and defrosting resistors fans (2);
- Terminal block for the connection with the devices constituting the machine: air evaporator and condensing unit. CO₂NNEXT;



3.1. Identification plate

To identify the machine, a specific EC identification plate has been applied on each partly-completed machine constituting the machine. The data reported on the registration plates of the components constituting the machine must be signalled to the Manufacturer's offices for each intervention requirement or to order spare parts.

As regards the identification plate of each component, please refer to the specific manual of the component itself.

3.1.1. Name

A B C D E F G H I L M
SN 045 M 1 45 X 0 2 1 1 00

A

Series SPLIT CO₂NNext

B

Size of compressor(s)

C

Type of application:

M = medium temperature (TN)

L = low temperature (BT)

D

Number of fans:

1 = one electronic motorised fan

2 = two electronic motorised fans

E

Diameter of the electronic motorised fans of the condensing unit:

450 mm

F

Refrigerant type: R744

G

Progressive no.

H

No. of gas cooler/capacitor rows

I

Expansion type: with thermostatic valve

L

Supply voltage:

1 = 230/1/50 + neutral

2 = 400/3/50 + neutral

M

Optional *

RIVACOLD

MASTERING COLD



***NOTE: For further regarding information, refer to UT.**

3.1.2. Technical data

As regards all the technical information about the components constituting the split system, please refer to the attached instruction manuals of each of them (Evaporators: Code 99212060-99212061 - condensing unit CO₂NNEXT code 99215071).

3.1.3. Noise

The data concerning the noise level is reported in the instruction manuals of the individual components of the split system. The presence of several machines installed in a confined environment increases the overall noise level.



ATTENTION: It is the PURCHASER's responsibility to carry out an assessment of the noise risk of their own activity as prescribed by the legislation in force in the place where the assembly is installed and to provide the operators with adequate Personal Protective Equipment (such as headphones for hearing protection).

RIVACOLD
MASTERING COLD

4. Transport and installation



DANGER: The operations indicated below must be carried out by qualified operators. The Manufacturer declines all responsibility for operations carried out without respecting the safety regulations, by unqualified operators and without compliance with the specifications of this manual.



ATTENTION: The user, having purchased the equipment, before use, becomes the person in charge of the component subject to Directive 2014/68/EU (PED) and must arrange for the legal checks to be performed according to the national legislation in force (Ministerial Decree 329 dated 1/12/2004 for Italy). For instance the start-up report, periodic checks, etc.



ATTENTION: With R744 (CO₂) type refrigerant, it is necessary for all operations to be carried out only by specialized technicians trained to operate with this type of substance.

Before incorporating the condensing units CO₂NNEXT, air evaporator and cell management panel on the final machine, it is however necessary to provide the power supplies and utilities necessary for the correct system functioning, following the instructions contained in this Chapter and, if necessary, previously consult with the Manufacturer's Technical Office.

4.1. Environmental requirements

Regarding the installation zone, the system does not have any particular restrictions from an environmental temperature viewpoint. The temperature can vary between -10°C ÷ +40°C.

The relative humidity must not exceed 50% with an ambient temperature of 40°C. Higher relative humidity levels are permitted for lower temperatures (example RH 90% with an ambient temperature of 20°C).

The machine cannot be installed above 1000 m altitude, unless otherwise specified.

The machine has been designed and built to work in environments where there is no potentially explosive atmosphere.

4.2. Power Supplies and Utilities

The power supplies and utilities (responsibility of the purchaser) necessary for operation of the machine consist exclusively of power supply.

Unless otherwise specified, the Purchaser must:

- prepare the means necessary to transport the machine to the assembly or installation place;
- prearrange the tools necessary for assembly and installation;
- provide the auxiliary equipment and consumables (use only water and cleaning cloths).

RIVACOLD
MASTERING COLD

4.3. Transport and handling

The instructions contained in this paragraph must be observed during the transportation and handling of the machine and during the assembling of all its components.



ATTENTION: During operations, the operator must use all the necessary Personal Protective Equipment (PPE).



DANGER: The following warnings must be observed during transportation or handling of the machine:

- the means used for lifting and transportation must be sized and suitable to the load being moved.
- during the transportation phase, check that the load is correctly balanced and that there are no parts that are not correctly fixed or at risk of damage.
- the machine structure shall result intact and completely assembled.
- check that the area intended for handling is clear and that there are no obstacles that could generate a dangerous situation.
- transiting and remaining under suspended loads is prohibited. Always place the machine on bearing surfaces suitable to support its weight.



DANGER: the lifting operations must be performed under the direct supervision of a qualified mechanical maintenance operator.



ATTENTION: During all these operations use the necessary caution to avoid collisions and tipping over, by handling the machine so as not to lose balance.



DANGER: Make sure there are no unauthorised personnel near the area where the lifting, handling, and unloading operations are taking place. Such persons must always remain at a safety distance.

RIVACOLD
MASTERING COLD

4.4. Installation



ATTENTION: The machine object of this manual is part of a refrigeration system consisting of the condensing unit and of refrigeration system components, as evaporator/s, pipe, safety components, etc.
The total volume of the evaporators associated with the machine must NOT exceed 9 litres.



ATTENTION: During operations, the operator must wear all the necessary Personal Protective Equipment (PPE).



DANGER: If the machine is installed in closed environments, a correct air circulation must be ensured. In addition, detecting and signalling acoustic and visible systems must be installed which may intervene in case of refrigerator gas leakage. Furthermore, for this type of installation, the constraints imposed by the laws of the installation country must be complied with.



DANGER: The installation surface must permanently support the weight of the machine, persons and equipment necessary for safe maintenance. Overloads should be considered in compliance with the conditions of the installation site and respecting the restrictions imposed by the laws of the country of installation.



DANGER: Perform the required interventions using appropriate work tools and paying the utmost attention to elements that could cause accidents and in compliance with the legislation in force in the country of installation.



DANGER: Places at a lower level and/or wells next to the machine installation place cannot be entered (in order to avoid that the potential gas leakage may channel, since the gas is heavier than air).



DANGER: The R744 (CO₂) refrigerant is colourless and odourless. Its presence in the environment can cause asphyxiation. All operations must be carried out using gas presence detectors and in compliance with the safety regulations of the country of installation.

Before proceeding with installation it is necessary to develop a refrigeration system housing project in which the following are defined:

- all components of the refrigeration system (e.g. condensing unit, air evaporator, pipes, safety components, etc.);
- all the power, command and communication power lines;
- location of the system;
- piping route (lay-out).

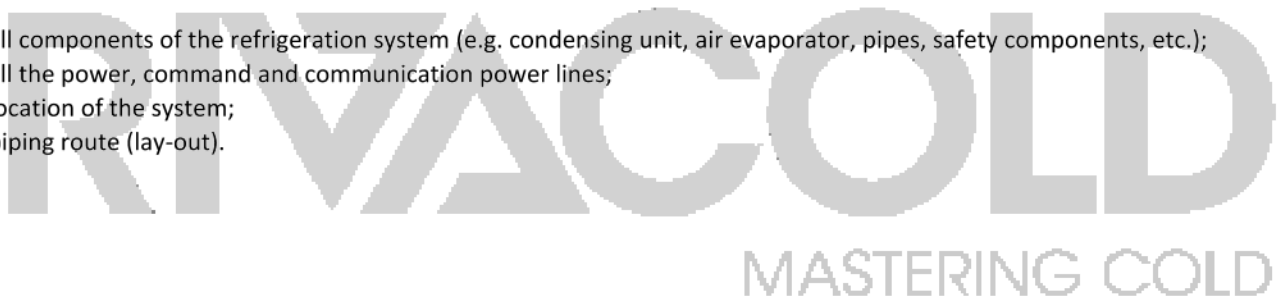

4.4.1. Cell management panel, power module and terminal block

The cell management panel consists of 3 modules regrouped by the manufacturer, identifying:

4. Part of air evaporator control management;
5. Power module;
6. Terminal block box.

Dimensions



Electric panel opening

By means of a screwdriver, gently remove the upper and lower mask (2), unscrew the four screws (1) and open the electric panel.

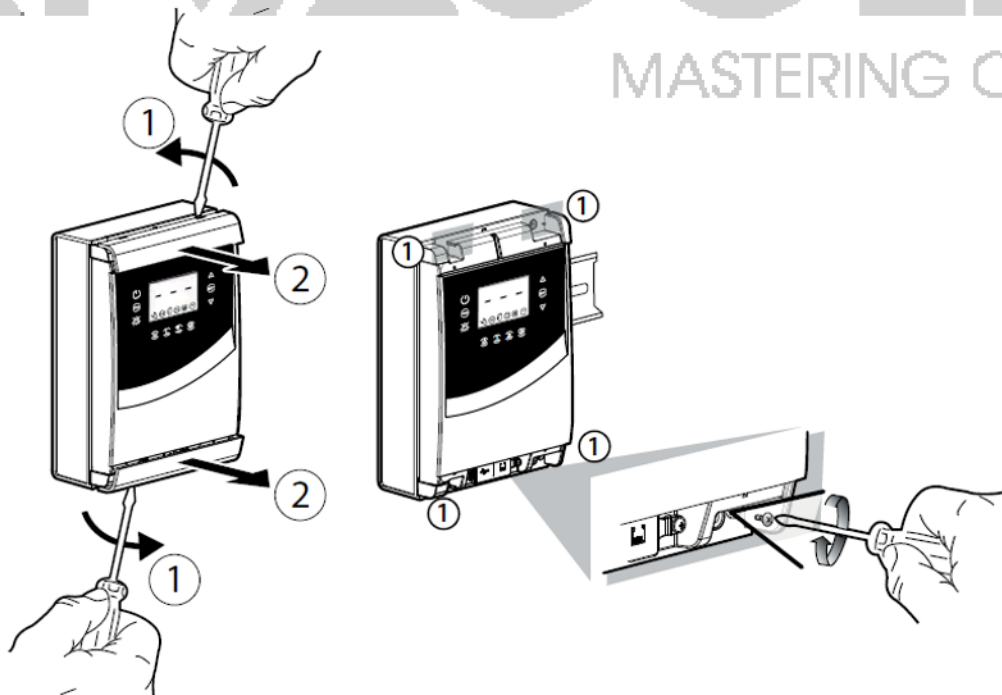

Mounting on DIN guide

Fix the DIN guide and insert the panel.

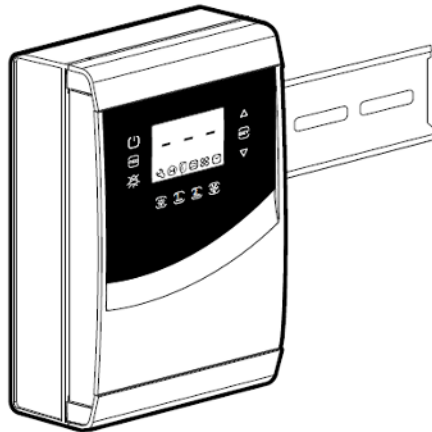

Wall mounting

Perform the holes (D. 4.5 mm) according to the drilling template above reported and insert the plugs (sizes in mm).

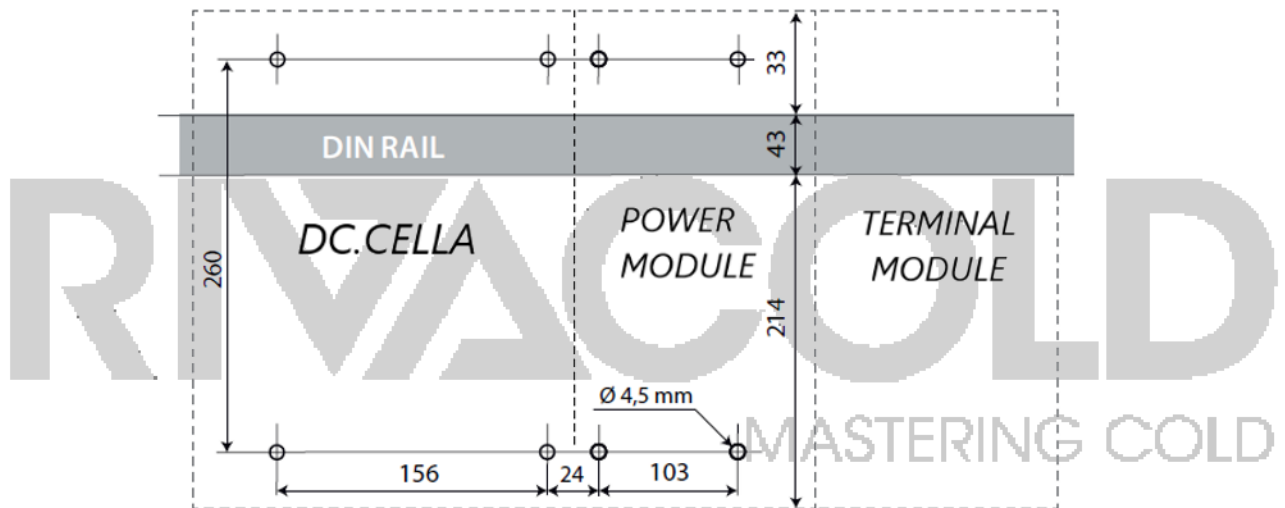

Cable passing

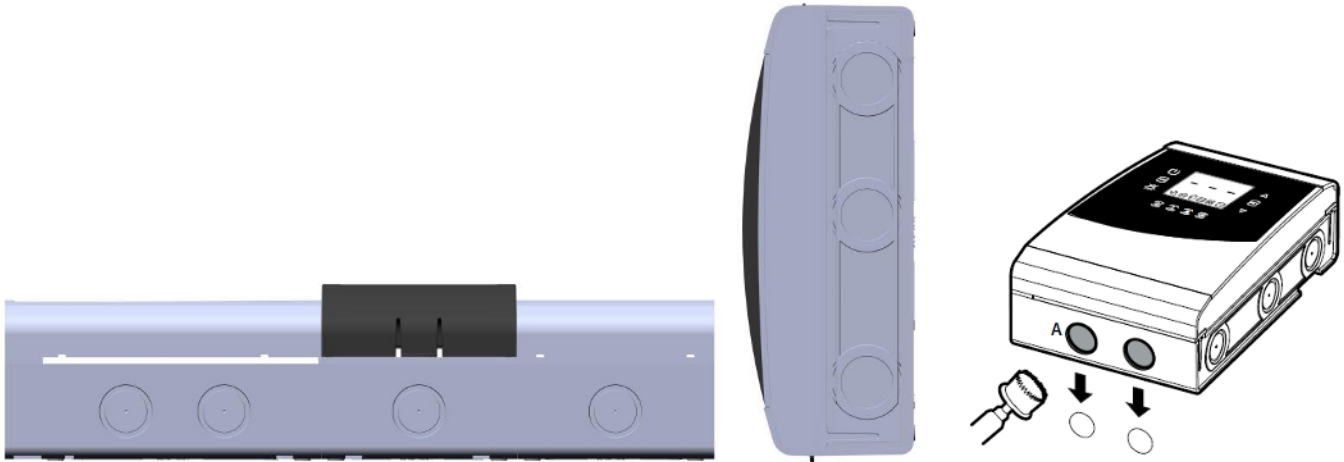

The hull of the cell external panel is equipped with holes for the cable passing. The final user can choose which pre-hole(s) use, at this point, pass the cables.



DANGER: The electrical connection operations must be carried out by qualified personnel who meet the necessary technical requirements established by the country in which the machine is installed.

The power supply supplied by the purchaser (voltage, phases and frequency) must be correct and sufficient to adequately power the machine. Specifically, it is necessary to adopt the following indications:

- Provide a differential magnetothermic switch for both the power supply lines placed upstream the condensing part and the evaporating part. These switches have to be adequately sized according to the current laws in the country of installation. Make sure that the supply voltage is the same as that shown on the plate and wiring diagram of the machine; the permissible tolerance is $\pm 10\%$ of the rated voltage. In case of presence on the machine of user devices that generate earth fault currents with high continuous and/or high frequency components (inverter, UPS, etc.), use a class differential thermal breaker suitable for use with such non-linear circuits.



ATTENTION: The differential thermal magnetic circuit breaker must be placed in the immediate vicinity of the machine (but outside the safety area) so that it can be clearly visible and reachable by the technician in case of maintenance.

- It is necessary that the section of the power supply cables is suitable to the power absorbed by the powered circuit. For further information on the total absorption of the machine, refer to the wiring diagram attached to this manual.
- The power supply cables shall have construction characteristics suitable to the machine installation environment conditions.

The machine is accompanied by No.2 electric power and control panels.

The electric panel of the condensing unit is equipped with the following functionalities:

- general switch with door lock;
- magnetothermic protection of all loads;
- electronic control terminal;
- compressors protected by magnetothermic switches;
- power transformer for control circuits;
- management of the maximum (and optional minimum) pressure switches each according to its functionality.

The electronic control allows to manage the:

- compressors;
- compressors working area;
- alarms;
- oil;
- low temperature system (if present).
- regulation with pressure or temperature probe

As regards all the information about the control and management condensation unit CO₂NNEXT electric panel, please refer to the attached documentation (code 99215071).

The electric panel to manage the evaporating part and the cell is equipped with the following functionalities

- magnetothermic protection of all loads;
- terminal connection block.

The electronic control allows to:

- adjust the cell temperature;
- manage the electronic thermostatic valve;
- alarms management;
- manage evaporator fans;
- manage the discharge resistance.

RIVACOLD
MASTERING COLD

4.4.2. Wiring of the various components of the system

The first electrical operations to be performed on the machine, even before powering it, are those of wiring the various devices that compose it.

The system is shipped with the three main components disconnected each other, therefore, besides the power supply of each component, the communication network must be wired.

More specifically, the connections to be carried out are:

- **GENERAL POWER SUPPLY**
 - Main power supply Condensing Unit;
 - Cell devices power supply: DC Cella Panel and air evaporator;
- **DC Cella Panel - Condensing Unit CO₂NNEXT CONNECTION**
 - RS-485 Network between condensing unit and DC Cella control;
- **DC Cella Panel - Air evaporator CONNECTION**
 - RS-485 Network between DC Cella control and EVD Ice (valve driver);
 - EVD Ice Driver power supply from DC Cella panel
 - Defrosting resistance power supply from DC Cella panel
 - Air evaporator fans and discharge resistance power supply from DC Cella panel

The manufacturer may provide a cable kit for the electrical connection of condensing unit, air evaporator and cell management panel. The document I-REUT-0002 will be attached, reporting the instructions to connect the components of the machine.

Where present, the instructions to connect the supervisory net are given below.



WARNING The cables lying must be performed in accordance to the laws in force in the country where it is installed and, where possible, it is recommended to avoid a common path between the cables for energy transportation to power supply the machine, or in general to power supply the motors (fans, electrovalves, etc.) and the cables for the transmission of signals (as network cables, 0/10V, etc.). Failure to comply with this provision could jeopardise correct functionality of the system due to serious capacitive couplings that disturb the communication of very low power.

Door switch connection

The door switch (not supplied by Rivacold) has been designed to be connected in the DC Cella panel through the Digital Input 1, terminal blocks No.21 and 40, as reported in the following connection diagram.

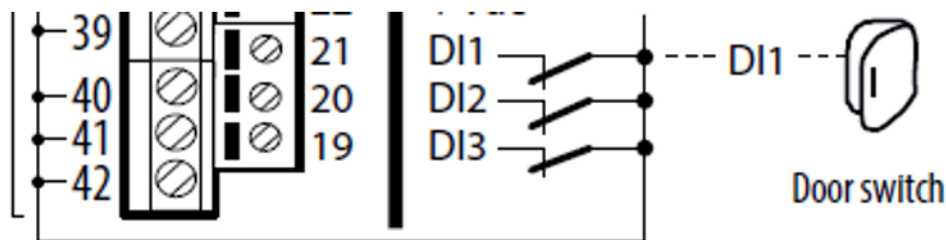

Once performed the connection, it is necessary to enable the dedicated function, bringing the parameter A3 to 0. For further information, consult the paragraph 4.6.13 "DOOR SWITCH FUNCTION ENABLING".

Humidity probe connection

In case of use of the humidity adjustment, by means of the pre-setting R05-R06-R07 selection, it is necessary to connect a humidity probe to the B5 input, as indicated in the following image.

The connection cable is not supplied by Rivacold.

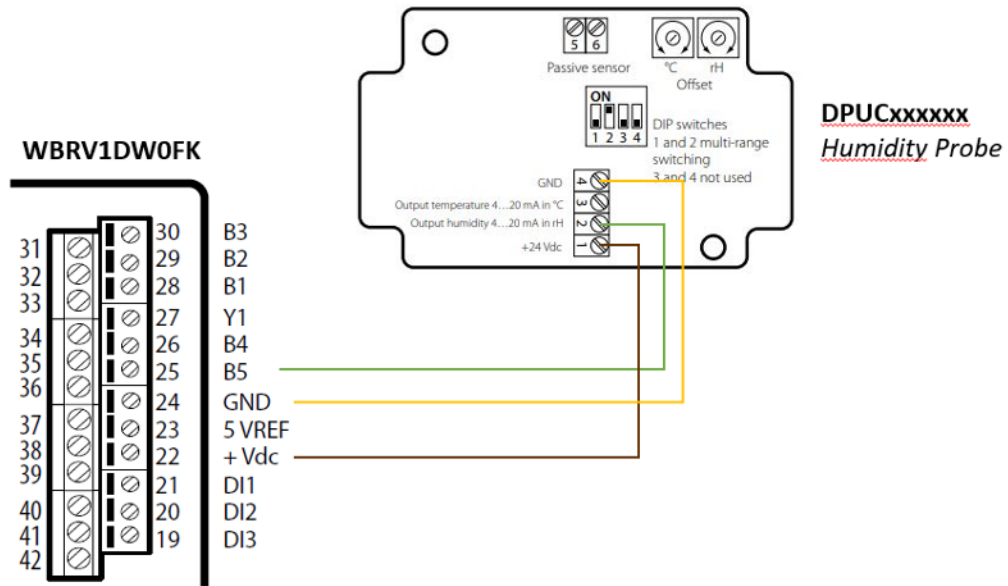

To know the ordering code of the humidity probe, please consult your own Rivacold provider.

Humidifier connection

In case of use of the humidity adjustment, by means of the pre-setting R05-R06-R07 selection, a connection for the humidifier consent is available too.

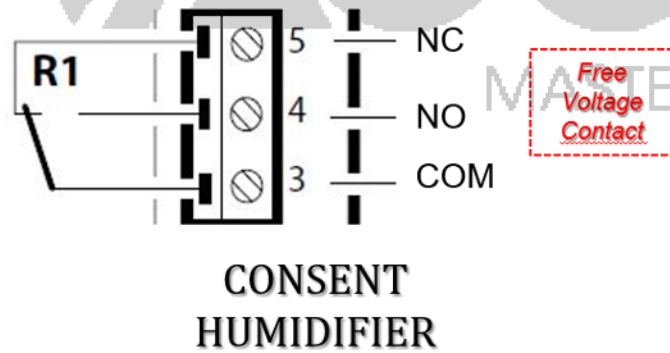

The contacts present are without tension, and both the contact NC and the contact NO are available.

Supervision network

For the wiring of the RS485 serial line on which the supervision network will sit, the following are recommended:

- use BELDEN 8762 AWG20 type cable;
- minimise the length of the serial line (RS485 max 1000m).

Do not create bifurcations of the line or star connections, as shown:

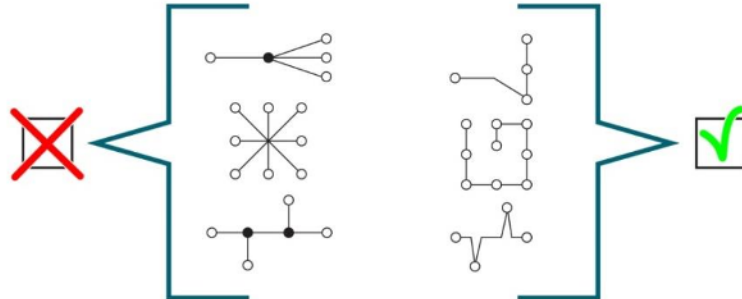

- Avoid to pass the serial cable next to the power cables, for which provide separated ducts for power and communication cables. It is necessary to maintain the cable far from devices which generate magnetic or electromagnetic fields, as radio aerials, transformers, contactors, neon lights, etc.
- Strictly respect the polarity of the "+" and "-" wires. Use the same colour for polarity; for example white wire for "+" and black for "-". The sheath must always only be connected to the dedicated terminal (usually called "GND" and near the "+" and "-" terminals). The two terminals must be connected to the GND terminal, that of the incoming cable and that of the outgoing cable.
- Avoid unsheathing the serial cable for an excessive length, as shown:

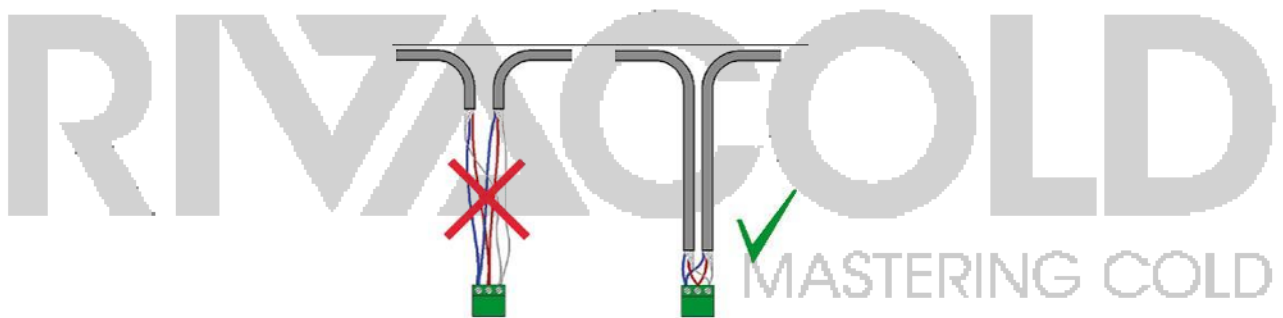

4.4.3. Refrigerating connection



ATTENTION: The pipes must be sized according to the type and extension of the system in full compliance with the safety restrictions imposed by the laws of the country of installation. The Manufacturer is not responsible for the incorrect selection and execution of the system pipes.

The machine must be connected to the following components to complete the entire system:

- TN positive evaporators;
- BT negative evaporators (if required);

The connections are as follows:

- liquid
- MT suction
- LT suction (if any)

The dimensions of the outlet pipes (intake line and liquid line) shown in the refrigeration diagram are calculated for a **MAXIMUM TUBING LENGTH** of 30 m.

This maximum length, valid for each individual section of both intake and liquid, has been defined in order to obtain a pressure drop that does not compromise correct functioning of the air evaporator.

Furthermore, the following functional requirements must be satisfied:

- the liquid line must be created in such a way that the refrigerant speed is between 0.6 and 1.2m/s and that the pressure drops are contained. It is advisable not to exceed 50kPa;
- the liquid line must be insulated with a suitable thickness and not less than 13 mm for medium temperature machines and 19mm for low temperature machines;
- the intake line from positive (if present) and/or negative (if present) users must be created in such a way that guarantees correct oil return to the partly-completed machine and to reduce pressure drops. It is advisable not to exceed 50kPa;

the intake lines must be insulated with a suitable thickness and be not less than 19mm.

RIVACOLD
MASTERING COLD

The following images show a number of explanatory notes for the installation of the described sections in order to guarantee a correct oil return by creating siphons and slopes.

- c. Evaporator placed at a **lower** level with respect to the condensing unit
- d. Evaporator placed at an **upper** level with respect to the condensing unit

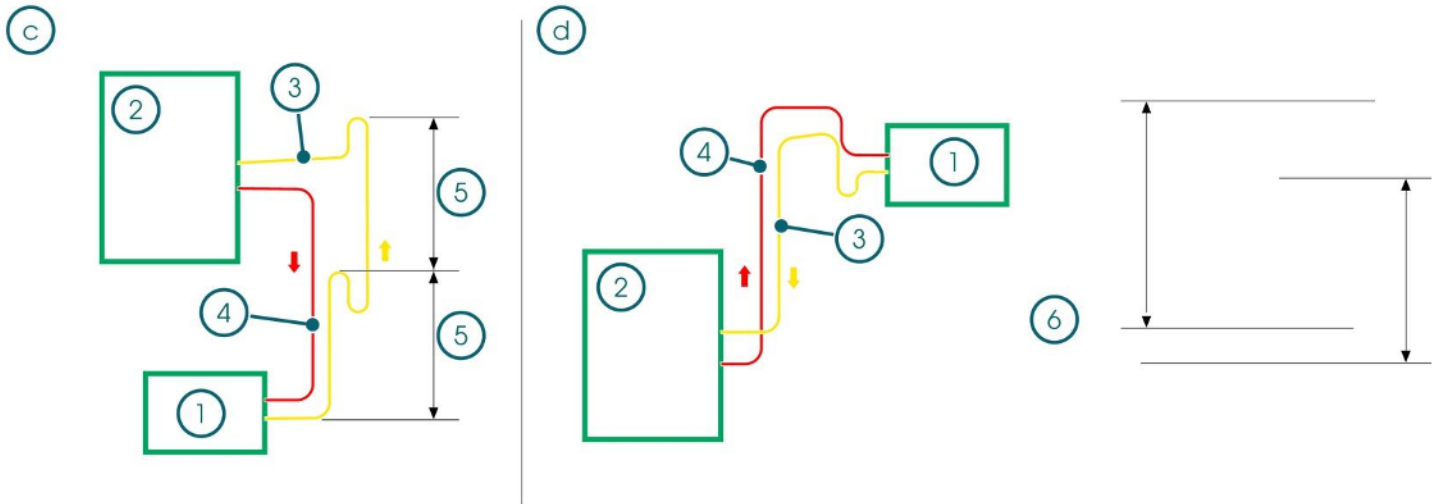

- | | |
|------------------|--|
| 1. Evaporator | 4. Return |
| 2. Central point | 5. Siphons minimum distance 2÷3 metres |
| 3. Supply | |

IMPORTANT

In the vertical section of the pipe **create siphons every 2÷3 metres**.

In the horizontal section, **carry out an inclination of 2÷3% in the pipe**, towards the refrigerant flow.

The connections are performed in such a way that welding or brazing can be carried out according to the type of material of the pipe being used. In general, steel requires welding, while other materials such as K65 or copper require brazing.



ATTENTION: Condensation unit and air evaporator are provided with nitrogen under pressure. Before working on the connections, remove the pressure by opening the appropriate service valves and acting on the pressure outlets in the circuit. If there is no pressure in the machine circuit, do NOT install and contact the manufacturer.



ATTENTION: Perform preparation of the connections by making a clean cut using appropriate tools.

Connections with the possibility of welding or brazing or with the possibility only of brazing

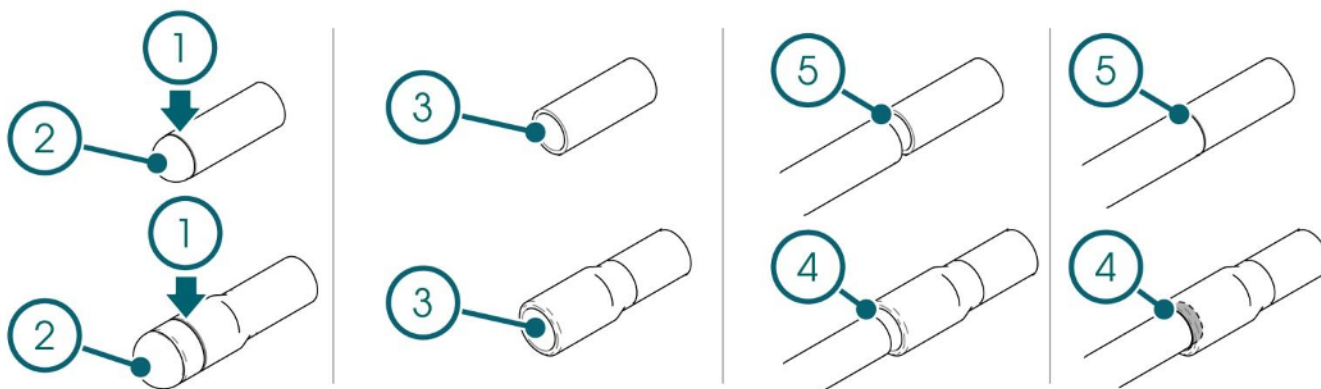

The information about the type of possible connection are reported in the refrigeration diagram of the condensing unit CO₂NNEXT. For further information in this regard, please refer to the relative manual (Code 99215071)

- | | |
|----------------------|--------------------------------------|
| 1. Pre-cut | 4. Connection with ODS brazing |
| 2. Closure cap | 5. Connection with head-head welding |
| 3. Connection points | |

RIVACOLD
MASTERING COLD

4.4.4. System drain

For the refrigerating machine and the compressors to work properly, it is essential to correctly vacuum the system to ensure a value of air and above all of humidity below the permissible values.

Introduction of the new gases required the use of polyester-based oils with characteristics of high hygroscopicity, necessitating greater attention in creating of the vacuum.

The duration of the draining phase is variable as it depends on several factors, but must nevertheless be at least 24 hours. In addition to reaching a vacuum level of at least 0.3 mbar it must remain constant over time.



The indicator present in the liquid line of the condensation unit, identified as ND1 of liquid passage, **MUST** result of green colour to signal the absence of humidity.



ATTENTION: Before proceeding to the vacuum phase, check that all the valves on the condensing unit and on the system are open.



ATTENTION: The drain phase can take place when the machine is not electrically powered.



ATTENTION: The potential removal of reels from the solenoid valves present on the condensing unit, must occur with machine disconnected. Only perform ignition after repositioning the coil on the solenoid valve.



ATTENTION: Do NOT start the compressors in vacuum conditions and without gas loaded, to avoid irreparable damage.

MASTERING COLD

For the correct vacuum procedure and for the condensing unit system opening, consult the manual CO₂NNEXT code 99215071. Instead, the steps to open manually the thermostatic valve on board the evaporator are given below. The following operations have to be performed directly by interfacing with the display of the condensing unit.

To force the thermostatic valve, follow these steps starting from the main screen of the electronic panel of the condensing unit:

	<p>Press the key</p>	
	<p>Press the key</p>	
	<p>Move down with the key</p>	
	<p>Move down with the key</p>	
	<p>Press the key</p>	
	<p>Select YES</p>	
	<p>Press again to confirm the selection</p>	
	<p>Select the value to be inserted (100% = 600 step)</p>	
	<p>Press again to confirm the selection</p>	
		

```
LT 10:33 04/07/18
evaporating: -9.9-barg
Par.suct: -30.0barg
Gas cooler: -30.0barg
LT: 0.0rps P: 0.0rps
Unit OFF by
keyboard
```

Press the key until returning to the main page



At this point, if the wiring has been carried out correctly, the EEV valve will move to the inserted opening until the initial situation is restored by setting NO at the "EEV Manual" parameter in mask Ead01.

RIVACOLD

MASTERING COLD

4.4.5. Refrigerant charge and oil

After the vacuum operation, the system shall be charged with carbon dioxide - CO₂ – R744 Purity ≥ 99,99%) H₂O ≤ 10 ppm, O₂ ≤ 10 ppm, N₂ ≤ 50 ppm or higher.

The refrigerant R744 (CO₂) is classified as safety class A1 according to EN 378-1 (non-flammable, non-toxic). ODP = 0 and GWP = 1. The high concentrations of CO₂ are dangerous. This refrigerant is odourless and colourless.



ATTENTION: The CO₂ refrigerant is heavier than air. The use of CO₂ detectors and a ventilation system is recommended if the machine is installed in a machines room or in areas where pockets of CO₂ might form (e.g. underground floors).



ATTENTION: The first phase of refrigerant load, or pre-load, must **ONLY** take place in the gaseous phase



For the refrigerant pre-charge phase it is necessary that:

- the machine is electrically power supplied in such a way that the solenoid valves of compressors YVEq.P YVEq.LT by pass (if present) are excited;
- the condensing unit and therefore the compressor and/or the compressors are in the OFF position from the electronic control keyboard;
- the valves HPV and VFL are manually opened by electronic control to guarantee opening of the entire refrigeration circuit.
- The thermostatic valve on-board the evaporator is manually opened by electronic control

During the refrigerator pre-charge phase it is necessary to insert CO₂ at gas state with a pressure value significantly above the triple point (5.185 bar(a)) in order to prevent the dry ice formation inside the system. It is recommended a gaseous pre-filling of 10 bar in the entire circuit.

The charge points are indicated in the manual of the condensing unit CO₂NNEXT. The reading of the pressure on each section is possible from the main screen of the electronic control.



ATTENTION: Do not power the solenoid valve coils if they are not installed on the valve itself.

RIVACOLD
MASTERING COLD

The next phase of loading consists of restoring the machine, putting the condensing unit and/or the compressors in ON from electronic control and following the steps provided in the chapter on starting up. So the charge can continue in liquid phase using the valves dedicated, as described in the manual of the condensing unit CO₂NNEXT code 99215071, RS3 valve and/or in gaseous phase on RS1, RS1.LT (if present). The utility must be enabled.



ATTENTION: The utilities must be already correctly set and programmed to be used with CO₂.



ATTENTION: Activate the utilities gradually during loading.



ATTENTION: During the loading phase the compressors will be activated and any alarms in the initial phase may be present.

- For the charge procedure, consult the manual of the condensing unit CO₂NNEXT code 99215071.



DANGER: For refrigerant filling, recovery and verification operations, wear gloves for protection against low temperatures. The filling operations must be performed only by specialized technicians.



DANGER: The R744 (CO₂) refrigerant is colourless and odourless. Its presence in the environment can cause asphyxiation. All operations must be carried out using gas presence detectors and in compliance with the safety regulations of the country of installation.

- The oil must be added according to the refrigerant charge as described in the manual of the condensing unit CO₂NNEXT code 99215071

RIVACOLD
MASTERING COLD

4.5. Preparation for start up



DANGER: The following operations must out be carried only by qualified and specifically trained technicians. The Manufacturer declines all responsibility for operations carried out without respecting the safety regulations, by unqualified operators and without compliance with the specifications of this manual.



ATTENTION: During operations, the operator must use all the necessary Personal Protective Equipment (PPE).



Before taking the machine to running speed, it is necessary to perform various checks at the moment of start-up.

Check valves

Make sure that all the valves on the condensing unit and on the system are open, that the service valves are closed and that they all are fitted with caps.

Check of the thermostatic valve utility

Ensure that all the electronic thermostatic valves of the utility are correctly programmed.



ATTENTION: The positive and negative utilities must have a minimum overheating of 5K and a correct MOP value on the expansion valve control to avoid increasing the intake pressure in the event of system shutdown. 35 bar - 1°C is recommended.

Electronic control: condensing unit and cell control

To start the system it is necessary to follow this sequence of operations:

- Start up the condensing unit as indicated in the instruction manual CO₂NNEXT code 99215071 and quick guide;
- at this point, start the cell control turning on its management-panel, as here reported.

RIVACOLD
MASTERING COLD

4.6. Cell management panel: DC Cella

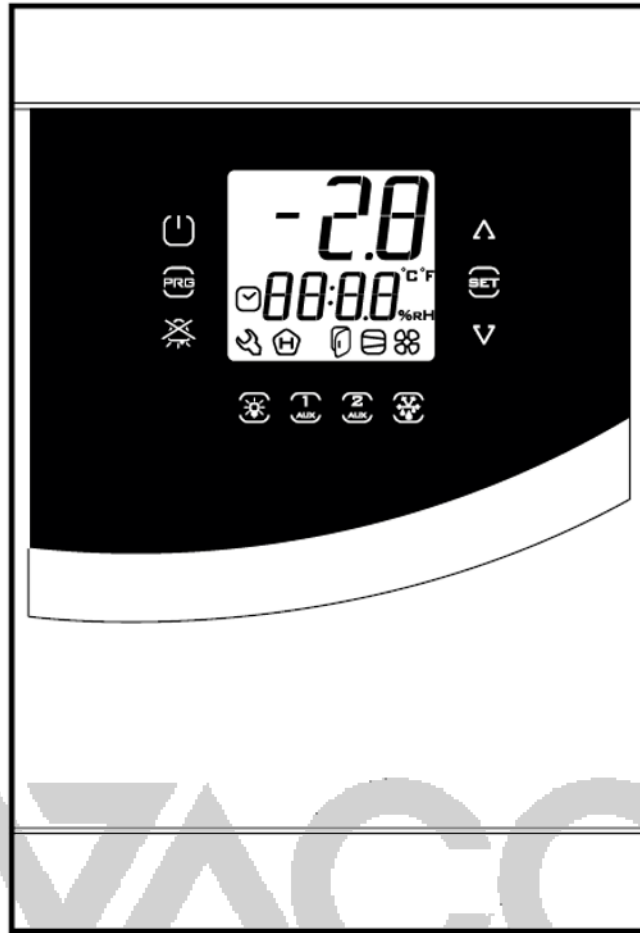

4.6.1. Display variables

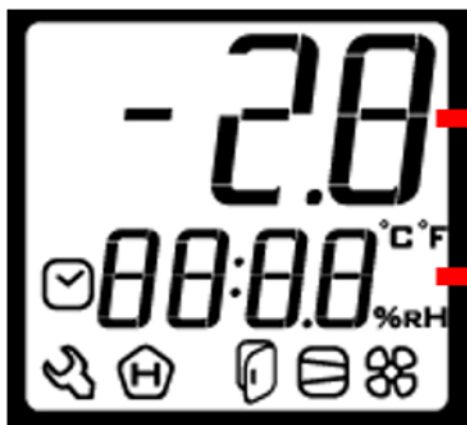

















CELL TEMPERATURE



**CELL SET POINT
% HUMIDITY (where required)**

4.6.2. Symbols and icons

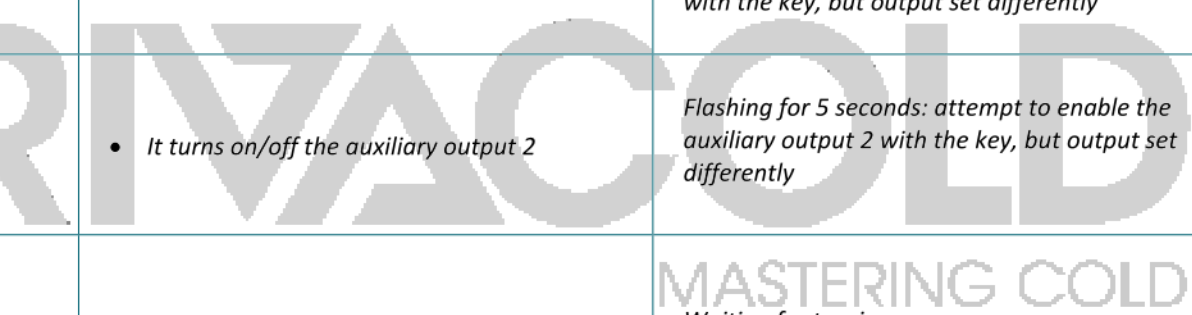
ICON	FUNCTION	NORMAL FUNCTIONING			NOTES
		ON	OFF	FLASHING	
	Assistance	-	-	Alarm, for example EEPROM and faulty probe	Serious problem detected. It is recommended to call the Technical Assistance.
	HACCP	HACCP function enabled	-	HACCP Alarm memorized (HA and/or HF)	
	Port	Door open	Door closed	Door open and alarm door open active	
	Compressor	On	Off	Waiting for turning on	It flashes when the insertion is delayed or impeded because of protection timing.
	Fan	On	Off	Waiting for turning on	It flashes when the insertion is delayed or impeded because of protection timing.
	Watch	Turned on if a timed defrosting is provided	-	-	
	Centigrade Degrees	Visualization of temperature in Centigrade Degrees	-	-	
	Fahrenheit Degrees	Visualization of temperature in Fahrenheit Degrees	-	-	
	Humidity percentage points	Humidity Value	-	-	

KEYS	ASSOCIATED FUNCTIONS	FLASHING
 ON/OFF	<ul style="list-style-type: none"> Pressed for 2 s, brings the control on OFF; Pressed for 2 s, brings the control on ON; 	
 PRG	<ul style="list-style-type: none"> ESC function, coming back to an upper level; Pressed for 2 s, you access the programming menu; Prg + Set: if pressed at the same time for 2s, you can access the multifunction menu 	
 ALARM	<ul style="list-style-type: none"> In case of alarm: it hushes up the acoustic alarm (Buzzer) and disables the alarm relay; Pressed for 2 s, it resets the alarms with manual reset; 	Visible only in case of alarm
 LIGHT	<ul style="list-style-type: none"> It turns on/off the light 	
1 AUX AUX1	<ul style="list-style-type: none"> It turns on/off the auxiliary output 1 	Flashing for 5 seconds: attempt to enable the auxiliary output 1 with the key, but output set differently
2 AUX AUX2	<ul style="list-style-type: none"> It turns on/off the auxiliary output 2 	Flashing for 5 seconds: attempt to enable the auxiliary output 2 with the key, but output set differently
 DEFROST	<ul style="list-style-type: none"> It enables/disables the manual defrosting 	 Waiting for turning on
 SET	<ul style="list-style-type: none"> Set point setting Value confirmation Prg + Set: if pressed at the same time for 2s, you can access the multifunction menu 	It indicates that the set point is not the one indicated by the St parameter, but it is defined by one of the following algorithms: <ul style="list-style-type: none"> Change of the set point from digital input (St+r4 and/or StH+r5) Change of the set point from time frame (St+r4 and/or StH+r5) Set point ramps (variable set point)
 UP/DOWN	<ul style="list-style-type: none"> Increase / decrease value (Flashing) 	The fix light signals that the AUX3 and/or AUX4 outputs are active. For further information, see paragraph 6.20.

4.6.3. First start-up







Before starting the system, check the following points:

- Connection of the serial cable (RS-485) between condensing unit CO₂NNEXT and DC Cella panel;
- Connection of the serial cable (RS-485) between EVD Ice driver and DC Cella panel;
- Connection resistance power cables and fans on the evaporator;
- Connection EVD Ice Driver power supply;

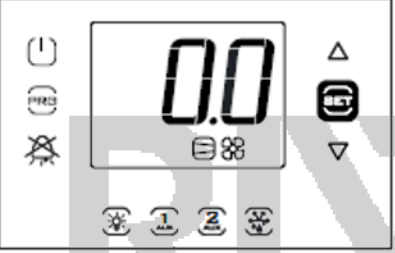
System turning on.

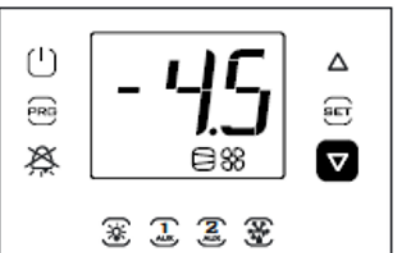
The DC Cella system will check the correct communication between all the devices. In case of signals of connection missing, please check again the serial network cabling.

4.6.4. Set point modification

 <p>Example image</p>	<p>Standard visualization</p>	
 <p>Example image</p>	<p>Pressing the SET key for 2 seconds</p>	
 <p>Example image</p>	<p>Press UP/DOWN to select the desired value</p>	
 <p>Example image</p>	<p>Press SET to confirm the new value, the display comes back to the standard visualization</p>	

4.6.5. RIVACOLD pre-settings selection

Rivacold offers its own customers a series of pre-settings suitable to every system and supply typology.

RIVACOLD PRE-SETTINGS		
R01	Standard Rivacold	Resistance defrosting with probe, evaporat. fans checked in temperature and stopped during the defrosting.
R02	Red Meats	Resistance defrosting with probe, evaporat. fans checked in temperature and stopped during the defrosting.
R03	Poultry	Resistance defrosting with probe, evaporat. fans checked in temperature and stopped during the defrosting.
R04	Fish	Resistance defrosting with probe, evaporat. fans checked in temperature and stopped during the defrosting.
R05	Vegetables	Resistance defrosting with probe, evaporat. fans turned on with compressor on and enabled during the defrosting, humidity control*
R06	Fruit	Time defrosting to stop compressor. evaporat. fans turned on with compressor and enabled during the defrosting, humidity control*.
R07	Summer and Tropical Fruit	No defrost, evaporat. fans turned on with compressor on, humidity control*.
R08	Frozen food	Resistance defrosting with probe, evaporat. fans turned on with compressor. on and stopped during defrosting.
R09	Restaurant Dining	Resistance defrosting with probe, evaporat. fans turned on with compressor on and enabled during the defrosting.
R10	Bread products	Resistance defrosting with probe, evaporat. fans controlled in temperature and stopped during defrosting.









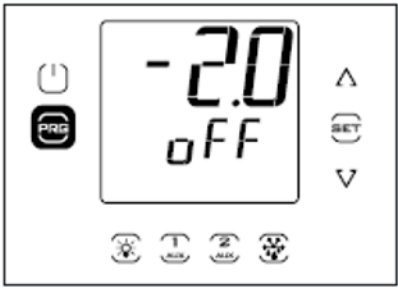
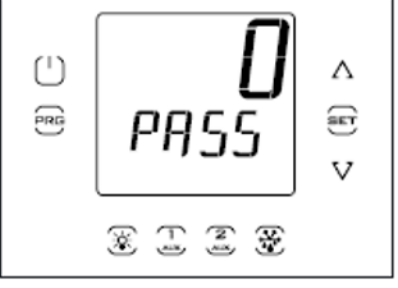

* In using one of these settings that require the humidity management, it is necessary to install the humidity probe and a humidifier. For further information, contact Rivacold.

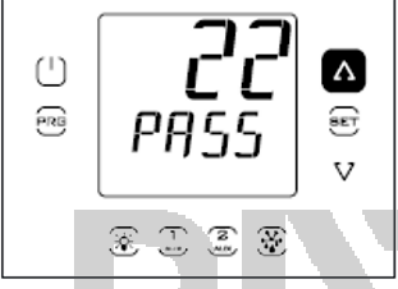



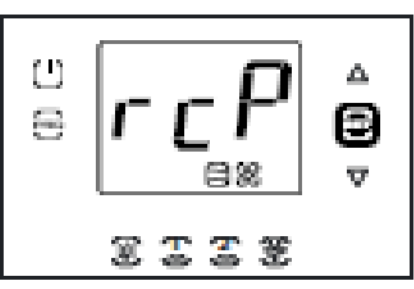

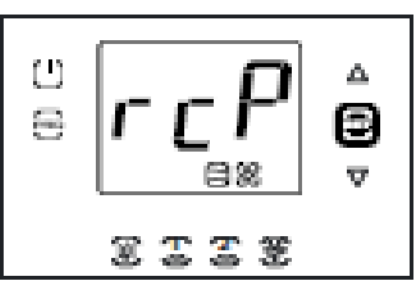

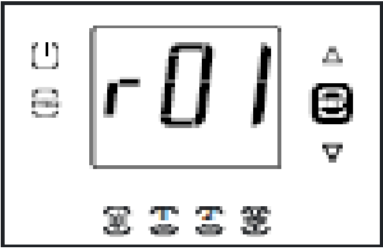

4.6.6. Pre-settings parameters

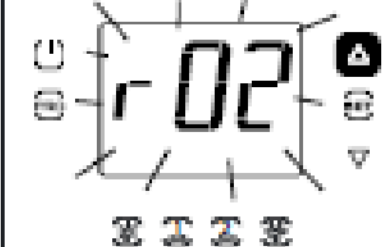
PAR.	RIVACOLD STANDARD	RED MEATS	POULTRY	FISH	VEGETABLES	FRUIT	SUMMER AND TROPICAL FRUIT	FROZEN FOOD	RESTAURANT DINING
/t2	6	6	6	6	6	6	11	6	6
/A2	1	1	1	1	1	0	0	1	1
St	-5	-0.5	0	1	4	4	10	-22	3
rd	4	2	2	2	2	2	2	2	2
r1	-25	-5	-5	-5	0	0	5	-25	0
r2	10	10	10	10	10	10	15	-15	10
r3	0	0	0	0	0	0	1	0	0
dl	6	12	12	12	24	24	8	15	13
dt1	15	20	15	10	8	4	4	15	10
dP1	30	60	60	60	45	30	30	60	90
AL	-10	4	4	4	4	5	5	10	4
AH	10	5	5	10	5	5	5	6	5
Ad	30	60	60	120	60	60	60	60	60
F0	3	3	3	3	0	0	0	0	0
F1	5	-8	0	0	5	5	5	5	5
F2	30	30	30	30	15	15	10	30	30
F3	1	1	1	1	0	0	0	1	0
H5	2	2	2	2	15	15	15	3	2
StH	90	90	90	90	95	95	85	90	90



The instructions to access the pre-settings selection are here reported.

	<p>Standard visualization</p>	
	<p>Press the PRG key for 2 seconds</p>	
	<p>Press UP/DOWN to insert the desired value.</p>	
	<p>Press SET to confirm the password value. The abbreviation of the parameters category will appear.</p>	
	<p>Press UP/DOWN to move between the parameters categories up to rcP.</p>	
	<p>Press SET to confirm the selected category and to display the relative parameters</p>	

	<p>Press SET to change the current configuration.</p>	
	<p>Press UP/DOWN to select the desired configuration.</p>	
	<p>Press SET to confirm the selected configuration.</p>	
	<p>Press once the PRG key, you come back to the parameters categories selection menu.</p>	
	<p>Pressing again PRG, you come back to the standard visualization.</p>	

4.6.7. Multifunction menu

The Dc Cella Control; is equipped with a multifunction menu which allows the quick access to the following functions:

CODE	MENU DESCRIPTION
HcP	HACCP alarm of HA and HF type visualisation and reset;
cc	Activation/deactivation of continuous cycle;
rEC	Maximum and minimum temperature visualization, deleting and restarting recording;
I/O	Input/output: temperature visualization read by the probes and digital inputs status;
USB	USB flash drive
InF	Information
Log	Data logging functions
SOF	Ultracella software updating







	<p>From the standard visualization press the PRG and SET keys for 2 seconds.</p>	
	<p>Select the desired menu through UP/DOWN.</p>	





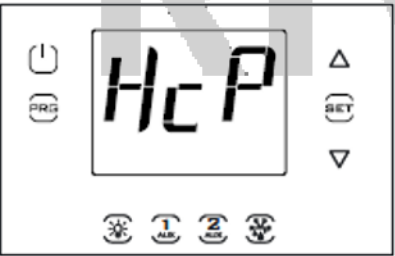

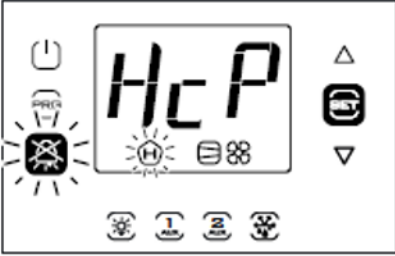
4.6.8. HACCP alarms visualization

Here below the HACCP menu parameters list:

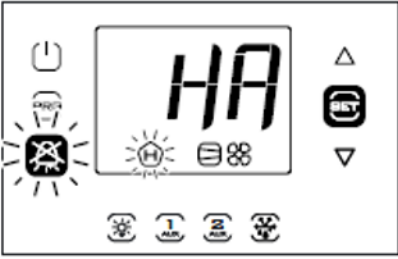
PAR.	DESCRIPTION
HA	Date/Hour last HA Alarm
HA1	Date/Hour penultimate HA Alarm
HA2	Date/Hour third to last HA Alarm
Han	HA Alarms number
HF	Date/Hour last HF Alarm
HF1	Date/Hour penultimate HF Alarm
HF2	Date/Hour third to last HF Alarm
HF _n	HF Alarms number
Hcr	HACCP alarms deleting

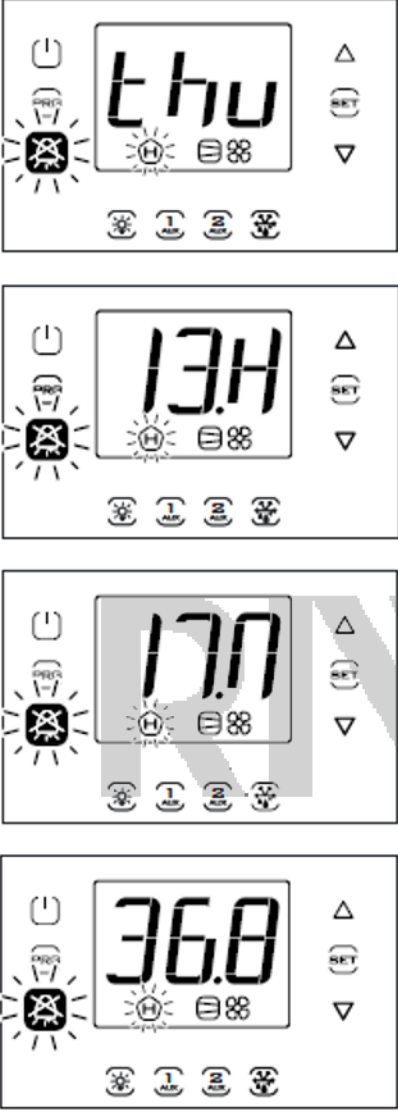
And the instructions to access the alarm visualization:

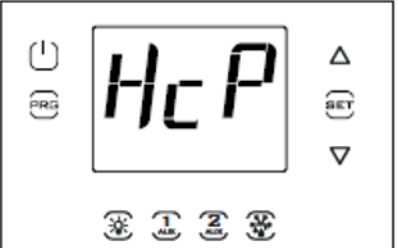
	<p>From the standard visualization press the PRG and SET keys for 2 seconds.</p>	
	<p>Select the HcP alarm through UP/DOWN</p>	
	<p>Press the SET key to enter the menu.</p>	

 <p>Example image</p>	<p>Select the desired parameter through the UP/DOWN keys.</p>	
 <p>Example image</p>	<p>At this point the display will show the following data scrolling:</p> <ul style="list-style-type: none"> • Day of the week; • Hour; • Minutes; • Temperature that caused the alarm 	
	<p>Select one or more times the PRG key to come back to the HcP menu</p>	

The above described procedure has taken as example an alarm of HA type occurred on Tuesday at 1:17 pm, with a detected temperature of 36.8°C.

4.6.9. Inputs and outputs status visualisation













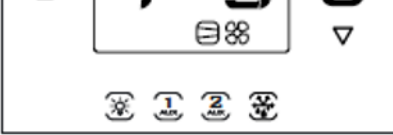

The DC Cella Control offers the possibility to visualise the inputs and outputs status of the I/O menu system. Here below the variables available for the reading:

VAR.	DESCRIPTION
b1	<i>Analog Input 1</i>
b2	<i>Analog Input 2</i>
b3	<i>Analog Input 3</i>
b4	<i>Analog Input 4</i>
b5	<i>Analog Input 5</i>
di1	<i>Digital Input 1</i>
di2	<i>Digital Input 2</i>
di3	<i>Digital Input 3</i>
do1	<i>Digital Output 1</i>
do2	<i>Digital Output 2</i>
do3	<i>Digital Output 3</i>
do4	<i>Digital Output 4</i>
do5	<i>Digital Output 5</i>
do6	<i>Digital Output 6</i>
Y1	<i>Analog Output 1</i>
ESu	<i>Temp. Aspiration EVD EVO</i>
ESA	<i>Temp. Evaporation EVD EVO</i>
ESH	<i>Overheating EVD EVO</i>
ISu	<i>Temp. Aspiration EVD Ice</i>
Isa	<i>Temp. Evaporation EVD Ice</i>
ISH	<i>Overheating EVD Ice</i>
U1	<i>Defrosting probe Sd1 (Only in the presence of 3PH module)</i>
U2	<i>Auxiliary defrosting probe Sd2 (Only in the presence of 3PH module)</i>
U3	<i>Condensing probe Sc (Only in the presence of 3PH module)</i>
dU4	<i>Motor-save (Only in the presence of 3PH module)</i>
dU5	<i>Pressure switch high / low pressure or Kriwan alarm (Only in the presence of 3PH module)</i>

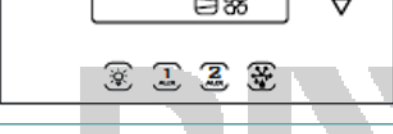

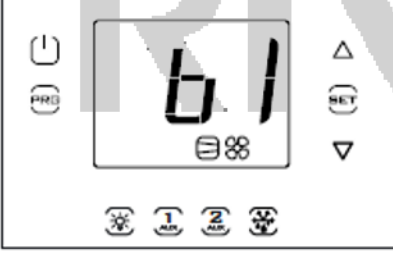

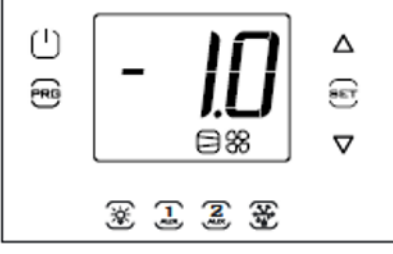
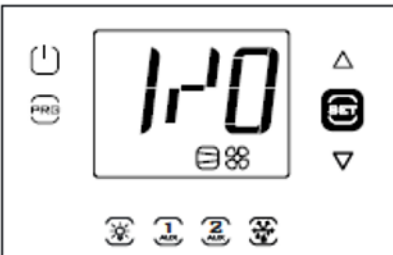
The digital inputs/outputs open are visualized with the writing "oP" (=open), the closed one with "cLo" (=closed).

Here below the instructions to access the I/O menu visualisation:

The above indicated procedure has taken as example the B1 probe visualisation.

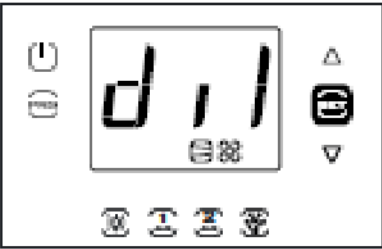
	<p>From the standard visualization press the PRG and SET keys for 2 seconds.</p>	
	<p>Select the <u>I/O</u> menu through UP/DOWN.</p>	
	<p>Press the SET key to enter the menu.</p>	
	<p>Select the desired variable using the UP/DOWN keys.</p>	
	<p>Press the SET key to display it.</p>	
	<p>At this point the display will show the following data scrolling:</p> <ul style="list-style-type: none"> • Variable name; • Value/Status; 	
		
	<p>Select one or more times the PRG key to come back to the <u>I/O</u> manu.</p>	

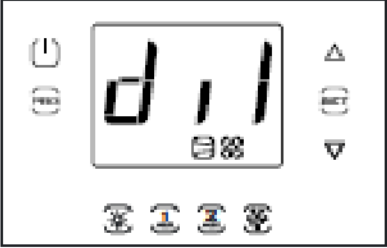
In case of digital input 1 visualisation, the visualisation is the following one:

	<p>Select the desired variable using the UP/DOWN keys.</p>	
 	<p>Press the SET key to display it.</p> <p>At this point the display will show the following data scrolling:</p> <ul style="list-style-type: none"> • Variable name; • Value/Status; 	

RIVACOLD
MASTERING COLD

4.6.10. **USB Functions**



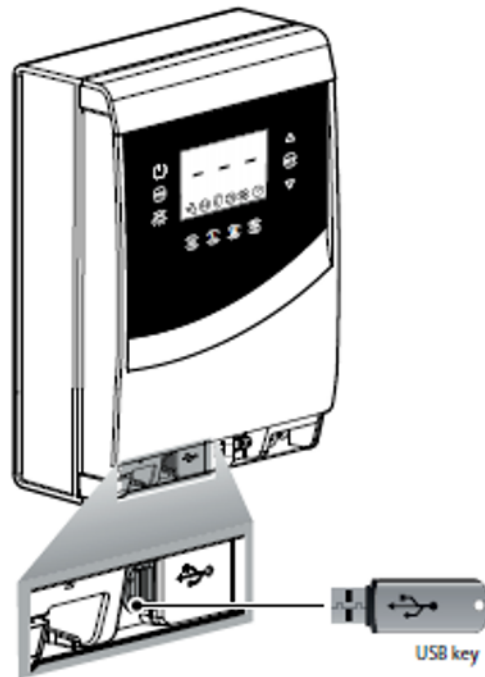

The DC Cella Control allows to load and unload the parameters and the alarm register through USB.

First of all, it is necessary to bring the control on OFF and dismount the front lower frame, as indicated in the following image.



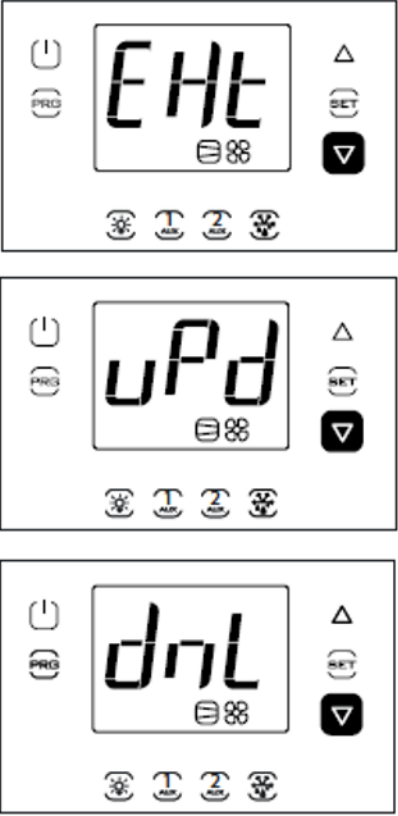





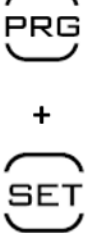

To load and unload the parameters, enter the multifunction menu, as indicated below.

<p>The control panel display shows a temperature of -2.0. The PRG key is highlighted on the left side of the panel.</p>	<p>From the standard visualization press the PRG and SET keys for 2 seconds.</p>	<p>The sequence of key presses: PRG (circled) followed by a plus sign (+) and SET (circled).</p>
<p>The control panel display shows 'USB'. The PRG key is highlighted on the left side of the panel.</p>	<p>Select the USB menu through UP/DOWN.</p>	<p>The sequence of key presses: an upward arrow (Δ) followed by a downward arrow (∇).</p>
<p>The control panel display shows 'rcP'. The PRG key is highlighted on the left side of the panel.</p>	<p>Select the voice rcP through the UP/DOWN keys.</p>	<p>The sequence of key presses: an upward arrow (Δ) followed by a downward arrow (∇).</p>
	<p>Press the SET key to display it.</p>	<p>The SET key (circled).</p>













 <p>The first three screenshots show the control panel with the following menu options displayed on the LCD: 'Ext', 'uPd', and 'dnL'. Each screen has a 'PRG' key on the left and 'UP' and 'DOWN' keys on the right. Below the LCD are four function keys.</p>	<p>Select the desired voice using the UP/DOWN keys.</p> <ul style="list-style-type: none"> • Ext: Exit the menu; • uPd: Upload from USB of the 10 parameters configurations; • dnL: Download in USB of the 10 parameters configurations 	
 <p>The fourth screenshot shows the control panel with the 'USB' menu option displayed on the LCD. The 'PRG' key is highlighted on the left side of the panel.</p>	<p>Select one or more times the PRG key to come back to the USB menu.</p>	

Instead, if you want to unload the alarm register, follow the instructions given below.

	<p>From the standard visualization press the PRG and SET keys for 2 seconds.</p>	
	<p>Select the ALG menu using UP/DOWN.</p>	
	<p>Press the SET key to start the unload operation.</p>	
	<p>The ALG writing will start flashing and the data will be saved inside the USB.</p>	
	<p>Once the operation will be concluded, the ALG writing will be fixed again and the green led next to the USB port will turn on. Disconnecting the USB drive, you will directly exit the menu.</p> <p>In case of error during the unloading phase, the alarm icon will turn on.</p>	
	<p>Select one or more times the PRG key to come back to the standard visualization.</p>	

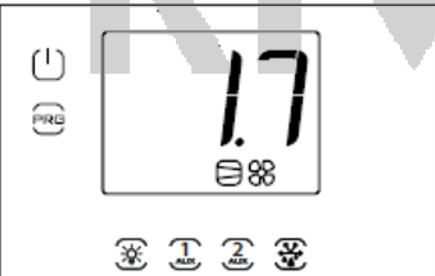
4.6.11. System information



In order to visualise the system information, follow the instruction given below:







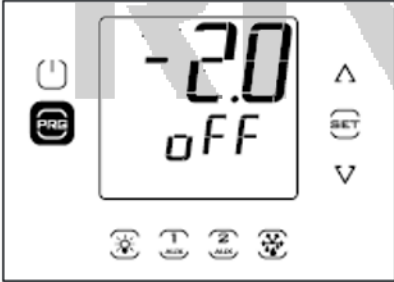
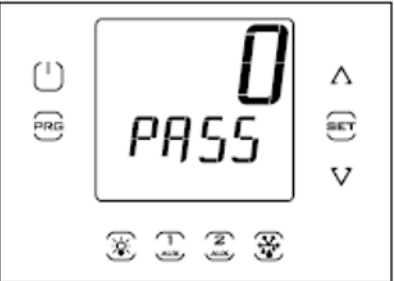



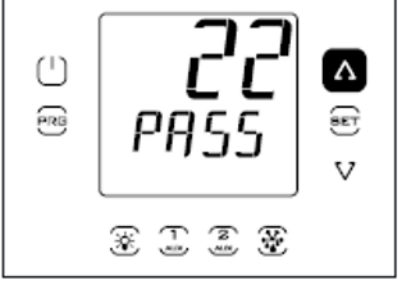

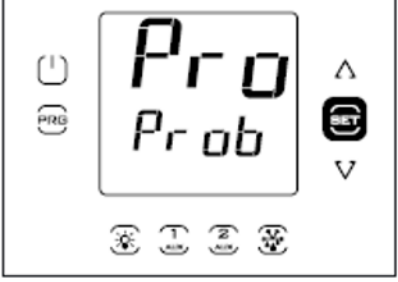
	<p>From the standard visualization press the PRG and SET keys for 2 seconds.</p>	
	<p>Select the InF menu using UP/DOWN.</p>	
	<p>Press the SET key to enter the menu.</p>	
	<p>Press the SET key to display it.</p>	
	<p>At this point the display will show the current software version of the control.</p>	
	<p>Select one or more times the PRG key to come back to the InF menu.</p>	



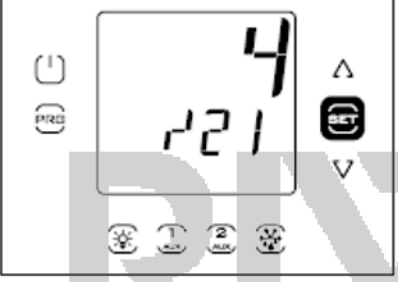

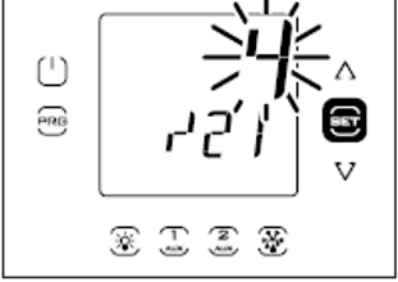

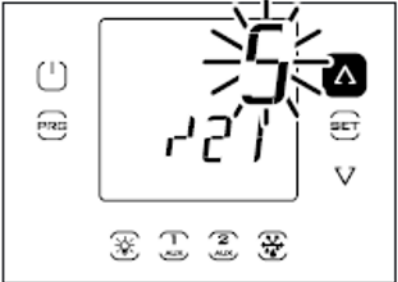
4.6.12. Access parameters modify

Here it is described the procedure to modify the parameters, which are subdivided in the categories above indicated:

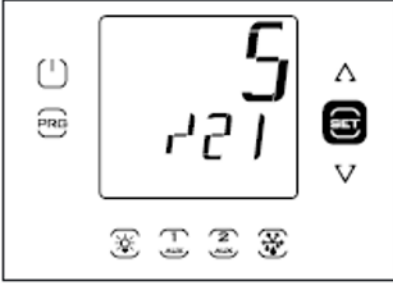
CATEGORY DESCRIPTION	CODE
PROBES	Pro
ADJUSTMENT	CtL
COMPRESSOR	CMP
DEFROSTING	dEF
ALARMS	ALM
FAN	FAn
HACCP	HcP
WATCH	rtc
DOOR AND LIGHT	doL
RECIPES	rcP
GENERIC FUNCTIONS	GEF
EVD EVO	EVO
EVDICE	ICE
THREE-PHASE MODULES	3PH
OUTPUT CONFIGURATION	OUT
HUMIDITY MANAGEMENT	HUM

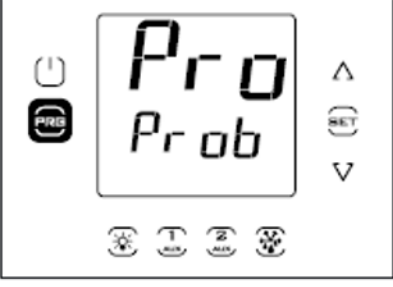
	<p>Standard visualization</p>	
	<p>Press the PRG key for 2 seconds</p>	









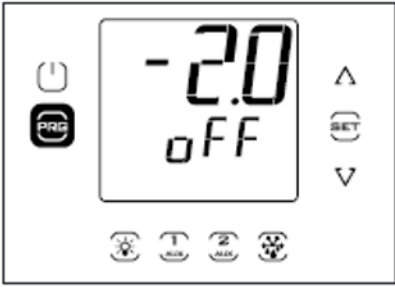
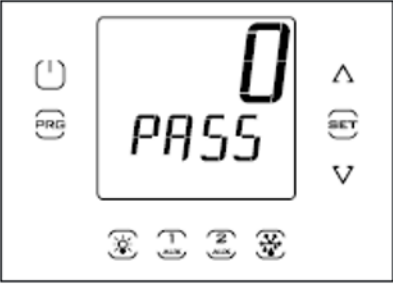

	<p>Press UP/DOWN to insert the desired value.</p>	
 <p>Example image</p>	<p>Press SET to confirm the value. The 1st line will show the abbreviation of the parameters category and the 2nd line will show the complete description of the category.</p> <p><i>See previous chapter for the complete list of parameters categories</i></p> <p>Press UP/DOWN to move between the parameters categories.</p> <p>Press SET to confirm the selected category and to display the relative parameters</p>	  
 <p>Example image</p>	<p>Press UP/DOWN to move between the parameters of the category.</p> <p>Press SET to enter the selected parameters category, the 1st line will show the current value of the first parameter of the category, while the 2nd line will show the parameter code and its description.</p>	 
 <p>Example image</p>	<p>Press SET to modify the value of the selected parameter.</p>	
 <p>Example image</p>	<p>Press UP/DOWN to insert the desired value.</p>	

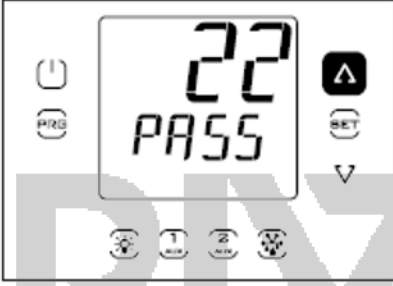





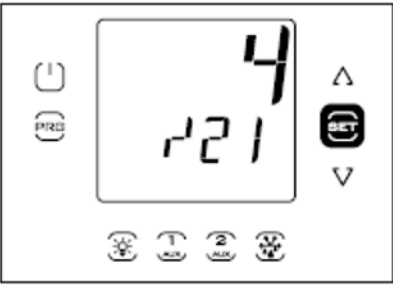

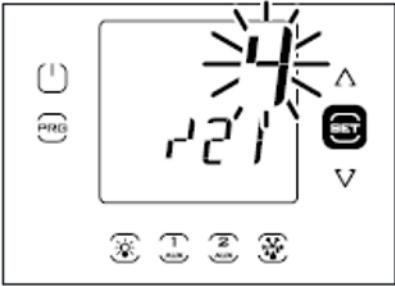

 <p><i>Example image</i></p>	<p>Press SET to confirm the new parameter value.</p>	
 <p><i>Example image</i></p>	<p>Press once the PRG key, you come back to the parameters categories selection menu.</p>	
	<p>Pressing again PRG, you come back to the standard visualization.</p>	

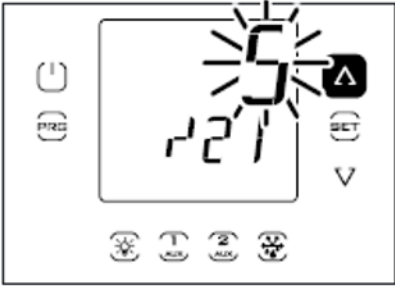
- If any key is pressed for 120 seconds, the control automatically comes back to the display standard visualization.
- During the parameters modification procedure, the new value is memorized every time that the SET key is pressed.

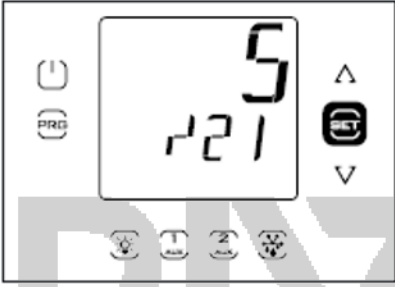
MASTERING COLD

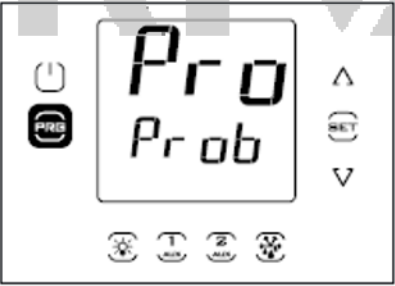
4.6.13. Door switch function enabling

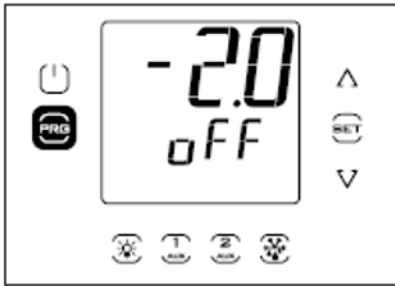
	<p>Standard visualization</p>	
	<p>Press the PRG key for 2 seconds</p>	
	<p>Press UP/DOWN to insert the desired value.</p>	
 <p><i>Example image</i></p>	<p>Press SET to confirm the value. The abbreviation of the parameters category will appear.</p>	
	<p>Press UP/DOWN to move between the parameters categories up to doL.</p>	
	<p>Press SET to confirm the selected category and to display the relative parameters</p>	
 <p><i>Example image</i></p>	<p>Press UP/DOWN to move between the category parameters up to the parameter A3.</p>	

 <p>Example image</p>	<p>Press SET to modify the parameter A3 value.</p>	
 <p>Example image</p>	<p>Press UP/DOWN to insert the value of 0.</p>	
 <p>Example image</p>	<p>Press SET to confirm the new parameter value.</p>	
 <p>Example image</p>	<p>Press once the PRG key, you come back to the parameters categories selection menu.</p>	
	<p>Pressing again PRG, you come back to the standard visualization.</p>	



NOTE: For further information about the functions and the control characteristics, consult the document “UltraCella Manual +0300083” available on the website **HYPERLINK:**

<http://www.Carel.com> www.Carel.com.

4.6.14. Parameters

PARAMETERS LIST

		<i>DESCRIPTION</i>	<i>MIN</i>	<i>MAX</i>	<i>UOM</i>	<i>TYPE</i>	<i>MODBUS SVP</i>	<i>R/W</i>	<i>RIVACOLD STANDARD</i>
Pro	/21	Probe measurement stability probe 1	0	9	-	I	51	R/W	4
	/22	Probe measurement stability probe 2	0	9	-	I	52	R/W	4
	/23	Probe measurement stability probe 3	0	9	-	I	53	R/W	4
	/24	Probe measurement stability probe 4	0	9	-	I	54	R/W	4
	/25	Probe measurement stability probe 5	0	9	-	I	55	R/W	4
	/4	Virtual probe composition 0 = probe B1 100= probe B2	0	100	-	I	56	R/W	0
	/U M	Unit of measure 0=°c/bar	0	0	-	I	-	-	0
	/6	Display decimal point 0/1 = yes/no	0	1	-	D	8	R/W	0
	/t1	Display variable 1 0 None 1 Virtual probe (Sv) 2 Outlet probe (Sm) 3 Intake probe (Sr) 4 Defrost probe 1 (Sd1) 5 Defrost probe 2 (Sd2) 6 Set point 7 B1 8 B2 9 B3 10 B4 11 B5 12 Condenser probe (Sc) 13 Variable speed condenser fans set point	0	13	-	I	106	R/W	1

/t2	Display variable 2 (*) 0 None 1 Virtual probe (Sv) 2 Outlet probe (Sm) 3 Intake probe (Sr) 4 Defrost probe 1 (Sd1) 5 Defrost probe 2 (Sd2) 6 Set point 7 B1 8 B2 9 B3 10 B4 11 B5 12 rd 13 Superheat (EVO) 14 Valve opening % (EVO) 15 Valve opening in steps (EVO) 16 Condenser probe (Sc) 17 Probe U1 (3ph mod.) 18 Probe U2 (3ph mod.) 19 Probe U3 (3ph mod.) 20 Variable condenser speed set point (Y1) 21 NOT USED 22 NOT USED 23 NOT USED 24 Humidity set point (*) can be viewed only on UltraCella Service Terminal or on the controller with double row display	0	24	-	I	107	R/W	6
/P	Type B1 to B3 0 NTC Standard range -50T90°C 1 NTC extended range 0T150°C 2 PT1000	0	2	-	I	59	R/W	0
/A2	B2 configuration 0 Absent 1 Defrost probe 1 (Sd1) 2 Intake probe (Sr) 3 Generic function on probe 2	0	3	-	I	60	R/W	1
/A3	B3 configuration 0 Absent 1 Defrost probe 2 (Sd2) 2 Condenser probe (Sc) 3 Defrost probe 1 (Sd1) 4 Ambient temperature probe (SA) 5 Generic function on probe 3	0	5	-	I	61	R/W	0
/P4	B4 type 0 NTC Standard range -50T90°C 1 NTC Extended range 0T150°C 2 0 to 10 V	0	2	-	I	62	R/W	0
/A4	B4 configuration 0 Absent 1 Ambient temperature probe (SA) 2 Humidity probe 3 Probe 4 generic temperature 4 Probe 4 generic humidity	0	4	-	I	63	R/W	0
/P5	B5 type 0 4 ... 20 mA 1 0 ... 5 Vrat 2 0.5 ... 4.5 Vrat	0	2	-	I	64	R/W	0

	/A5	B5 configuration 0 Absent 1 Humidity probe 2 Probe 5 generic temperature 3 Probe 5 generic humidity 4 Probe 5 generic pressure 5 Scp (Condensing pressure probe)	0	5	-	I	65	R/W	0
	/4L	Probe 4 minimum value	- 50.0	/4H	-	A	208	R/W	0
	/4H	Probe 4 maximum value	/4L	200	-	A	209	R/W	100
	/5L	Probe 5 minimum value	- 50.0	/5H	-	A	210	R/W	0
	/5H	Probe 5 maximum value	/5L	999	-	A	211	R/W	100
	/C1	Offset B1	- 20.0	20.0	°C / ° F	A	0	R/W	0
	/C2	Offset B2	- 20.0	20.0	°C / ° F	A	1	R/W	0
	/C3	Offset B3	- 20.0	20.0	°C / ° F	A	2	R/W	0
	/C4	Offset B4	- 20.0	20.0	°C/°F/ %Rh	A	3	R/W	0
	/C5	Offset B5	- 20.0	20.0	°C/°F/ %Rh bar/psi	A	4	R/W	0
Ctl	St	Set point	r1	r2	°C / ° F	A	5	R/W	-5
	rd	Differential	0.1	20	°C / ° F	A	6	R/W	4
	r1	Minimum set point	- 50.0	r2	°C / ° F	A	7	R/W	-25
	r2	Maximum set point	r1	200	°C / ° F	A	8	R/W	10
	r3	Operating mode 0 direct with defrost 1 direct without defrost	0	1	-	D	0	R/W	0
	rn	Dead band	0	60	°C / ° F	A	190	R/W	0
	rr	Differential for control with dead band	0.1	20	°C / ° F	A	191	R/W	2
	r4	Offset set point	60	60	°C / ° F	A	192	R/W	3
	PS1	Ramps: final set point, phase 1	- 50.0	200.0	°C / ° F	A	187	R/W	0
	PS2	Ramps: final set point, phase 2	- 50.0	200.0	°C / ° F	A	188	R/W	0
	PS3	Ramps: final set point, phase 3	- 50.0	-200.0	-	A	189	R/W	-30
	PH1	Ramps: duration of phase 1	0	10	days	A	212	R/W	6
PH2	Ramps: duration of phase 2	0	10	days	A	213	R/W	2	

	PH3	Ramps: duration of phase 3	0	10	days	A	214	R/W	10
	Pdt	Ramps: maximum set point variation after blackout	10.0	30.0	°C / ° F	A	216	R/W	20
	Pon	Enable set point ramps 0/1 = ramps disabled/enabled	0	1	-	D	48	R/W	0
	c4	Reg.runn. time in duty setting	0	100	h	I	74	R/W	0
	cc	Continuous cycle duration	0	15	h	I	75	R/W	0
	c6	Low temp. alarm delay after cc	0	250	h	I	76	R/W	2
CdU	SPF	Evaporation setpoint	SPN	SPX	bar	A	1126	R/W	4.2
	SPN	Floating suction - minimum setpoint	2.7	SPX	bar	A	1127	R/W	3.8
	SPX	Floating suction - maximum setpoint	SPN	4.2	bar	A	1128	R/W	4.2
dEF	d0	Type of defrost 0 Heater by temperature 1 Hot gas by temperature 2 Heater by time 3 Hot gas by time	0	3	-	I	80	R/W	0
	dl	Max interval between consecutive defrosts 0 = defrost not performed	0	250	hours	I	81	R/W	6
	dt1	End defrost temperature, main evaporator	- 50.0	200.0	°C / ° F	A	10	R/W	15
	dt2	End defrost temperature, auxiliary evaporator	- 50.0	200.0	°C / ° F	A	11	R/W	4
	dP1	Maximum defrost duration	1	250	min	I	82	R/W	30
	dP2	Maximum defrost duration, auxiliary evaporator	1	250	min	I	83	R/W	30
	dd	Dripping time after defrost	0	30	min	I	84	R/W	2
	d3	Defrost activation delay	0	250	min	I	85	R/W	0
	dpr	Defrost priority over continuous cycle 0/1 = no/yes	0	1	-	D	4	R/W	1
	d4	Defrost at start-up 0/1=no/yes	0	1	-	D	3	R/W	0
	d5	Defrost delay at start-up	0	250	min	I	86	R/W	0
	d6	Terminal display during defrost 0 Temperature alternated with dEF 1 Last temperature shown before defrost 2 dEF	0	2	-	I	88	R/W	0
	d8	High temperature alarm delay after defrost (and door open)	0	250	hours	I	87	R/W	30
	d13	Defrost on two evaporators (0=Simultaneous - 1=Separate)	0	1	/	D	63	R/W	1
d10	Defrost time in running time mode 0=Function disabled	0	240	min	I	1132	R/W	0	

	d11	Defrost temp. thresh. in running time mode	- 50.0	50.0	°C	A	1134	R/W	-30
	d7	Enable Skip defrost 0=Function disabled	0	1	/	D	1205	R/W	0
	dn	Nominal defrost duration	5	100	%	I	1129	R/W	75
	de	Maximum number of defrost evaluations	2	50	/	I	1137	R/W	3
ALM	A0	Alarm and fan differential	0.1	20.0	°C / ° F	A	12	R/W	2
	A1	Alarm thresholds (AL, AH) relative to set point or absolute 0/1=relative/absolute	0	1	-	D	5	R/W	0
	AL	Low temperature alarm threshold If A1=0, AL=0: alarm disabled If A1=1, AL=-50: alarm disabled	- 50.0	200.0	°C / ° F	A	13	R/W	-10
	AH	High temperature alarm threshold If A1=0, AH=0: alarm disabled If A1=1, AH=200: alarm disabled	- 50.0	200.0	°C / ° F	A	14	R/W	10
	Ad	High/low temperature alarm delay	0	250	min	I	89	R/W	30
	A5	Digital input 2 (DI2) configuration 0 Inactive 1 Immediate external alarm 2 Do not select 3 Enable defrost 4 Start defrost 5 Door switch (enable A3) 6 Remote ON/OFF 7 Change set point 8 Low pressure switch 9 Do not select 10 Do not select 11 Do not select 12 Activate AUX 13 Do not select 14 Activate continuous cycle 15 Alarm from generic function 16 Start/stop defrost 17 Serious alarm	0	17	-	I	90	R/W	0
	A6	Stop compressor on external alarm	0	100	min	I	92	R/W	0
	A7	Low pressure (LP) alarm delay	0	250	min	I	93	R/W	1
	A8	Enable Ed1 and Ed2 alarms 0/1= disabled/enabled alarms	0	1	-	D	57	R/W	0

	A9	Digital input 3 (DI3) configuration 0 Inactive 1 Immediate external alarm 2 Do not select 3 Enable defrost 4 Start defrost 5 Door switch (enable A3) 6 Remote ON/OFF 7 Change set point 8 Low pressure switch 9 Do not select 10 Do not select 11 Do not select 12 Activate AUX 13 Do not select 14 Activate continuous cycle 15 Alarm from generic function 16 Start/stop defrost 17 Serious alarm	0	17	-	I	91	R/W	0
	A10	Low pressure alarm delay (LP), compressor running	0	60	min	I	94	R/W	3
	Ac	High temperature condenser alarm threshold	- 50.0	200.0	°C / ° F	A	15	R/W	70
	Acd	High temperature condenser alarm delay	0	250	min	I	95	R/W	0
	ULL	Absolute low humidity alarm threshold 0= alarm disabled	0	100.0	%rH	A	194	R/W	0
	UHL	Absolute high humidity alarm threshold 100= alarm disabled	0	100.0	%rH	A	193	R/W	100
	Ad H	Humidity alarms AUH, AUL delay	0	250	min	A	227	R/W	120
	A11	Digital input 1 configuration (DI1)	0	17	/	A	279	R/W	5
Fan	F0	Evaporator fan management 0 (ON-OFF) always on with compressor on 1 (ON-OFF) activation based on Sd, Sv 2 (MODULATING) variable speed based on Sd 3 (ON-OFF) activation based on Sd 4 (ON-OFF) always on 5 (ON-OFF) activation with temp. / humidity control 6 (MODULATING) variable speed fans based on Sd-Sv 7 (MODULATING) variable speed fans based on Sv	0	2	-	I	265	R/W	3
	F1	Fan activation temperature	- 50.0	200.0	°C / ° F	A	16	R/W	5
	Frd	Fan activation differential	0.1	20.0	°C / ° F	A	17	R/W	2
	F2	Fan activation time with compressor off	0	60	min	I	96	R/W	30
	F3	Evaporator fan during defrost 0/1= ON/OFF	0	1	-	D	6	R/W	1
	Fd	Post dripping time	0	30	min	I	99	R/W	1
	F5	Evaporator fans cut-off temperature (hysteresis 1°C)	-50	200	°C / ° F	A	18	R/W	15

	F6	Maximum fan speed	F7	100	%	I	97	R/W	100
	F7	Minimum fan speed	0	F6	%	I	98	R/W	0
	F8	Fans peak time 0 = disabled function	0	240	s	I	175	R/W	0
	F10	Evaporator fans forcing time at maximum speed 0 = disabled function	0	240	min	I	176	R/W	0
CnF	H0	Serial address	0	247	-	I	108	R	193
	In	Type of unit	0	0	-	-	-	R	0
	H1	AUX1 output configuration 0 Normally energised alarm 1 Normally de-energised alarm 2 Activate from AUX button or DI 3 Activate collection pan heater 4 Auxiliary evaporator defrost 5 Pump down valve 6 Condenser fan 7 Delayed compressor 8 Control output 1 ON/OFF 9 Control output 2 ON/OFF 10 Alarm output 1 11 Alarm output 2 12 Do not select 13 Second compressor step 14 Second compressor step with rotation 15 Humidity output 16 Reverse mode output 17 Output managed by time band 18 Control output 3 ON/OFF 19 Reverse output - dehumidification 20 External dehumidifier 21 Reverse mode output 2	0	21	-	I	100	R/W	3
	H4	Buzzer 0/1 = enabled/ disabled	0	1	-	D	10	R/W	0

H5	AUX2 output configuration 0 Normally energised alarm 1 Normally de-energised alarm 2 Activate from AUX button or DI 3 Activate collection pan heater 4 Auxiliary evaporator defrost 5 Pump down valve 6 Condenser fan 7 Delayed compressor 8 Control output 1 ON/OFF 9 Control output 2 ON/OFF 10 Alarm output 1 11 Alarm output 2 12 Do not select 13 Second compressor step 14 Second compressor step with rotation 15 Humidity output 16 Reverse mode output 17 Output managed by time band 18 Control output 3 ON/OFF 19 Reverse output - dehumidification 20 External dehumidifier 21 Reverse mode output 2	0	21	-	I	101	R/W	2
H6	Terminal keys block configuration 0 all keys enabled 1 Set point modification 2 Defrost 4 - 8 AUX1 output 16 PRG+SET (menu) 32 AUX2 output 64 ON/OFF management 128 Light management 255 all keys disabled	0	255	-	I	109	R/W	0
HO 1	Output Y1 configuration 0 Not active 1 Modulating output 1 (generic function) 2 Variable speed evaporator fans set on Sd probe 3 Variable speed condenser fans	0	3	-	I	102	R/W	0
H7	BMS protocol selection On DCCCELLA Fix @ MODBUS							
H10	BMS baud rate bit/s On DCCCELLA Fix @ 19200							
H11	BMS stop bits On DCCCELLA Fix 2 STOP BIT							
H12	BMS parity On DCCCELLA Fix ODD							
tr1	First temperature to be recorded 0 No log 1 Sv 2 Sm 3 Sr 4 Sd1 5 Sd2 6 Sc 7 SA 8 Su	0	8	-	I	181	R/W	0

tr2	<p>Second temperature to be recorded</p> <p>0 No log</p> <p>1 Sv</p> <p>2 Sm</p> <p>3 Sr</p> <p>4 Sd1</p> <p>5 Sd2</p> <p>6 Sc</p> <p>7 SA</p> <p>8 Su</p>	0	8	-	I	182	R/W	0
trc	Sample time temperature recording	2	60	min	I	183	R/W	5
H13	<p>AUX3 output configuration</p> <p>0 Normally energised alarm</p> <p>1 Normally de-energised alarm</p> <p>2 Cannot be selected</p> <p>3 Activate collection pan heater</p> <p>4 Auxiliary evaporator defrost</p> <p>5 Pump down valve</p> <p>6 Condenser fan</p> <p>7 Delayed compressor</p> <p>8 Control output 1 ON/OFF</p> <p>9 Control output 2 ON/OFF</p> <p>10 Alarm output 1</p> <p>11 Alarm output 2</p> <p>12 Do not select</p> <p>13 Second compressor step</p> <p>14 Second compressor step with rotation</p> <p>15 Humidity output</p> <p>16 Reverse mode output</p> <p>17 Output managed by time band</p> <p>18 Control output 3 ON/OFF</p> <p>19 Reverse output - dehumidification</p> <p>20 External dehumidifier</p> <p>21 Reverse mode output 2</p>	0	21	/	A	271	R/W	2
H14	<p>AUX4 output configuration</p> <p>0 Normally energised alarm</p> <p>1 Normally de-energised alarm</p> <p>2 Cannot be selected</p> <p>3 Activate collection pan heater</p> <p>4 Auxiliary evaporator defrost</p> <p>5 Pump down valve</p> <p>6 Condenser fan</p> <p>7 Delayed compressor</p> <p>8 Control output 1 ON/OFF</p> <p>9 Control output 2 ON/OFF</p> <p>10 Alarm output 1</p> <p>11 Alarm output 2</p> <p>12 Do not select</p> <p>13 Second compressor step</p> <p>14 Second compressor step with rotation</p> <p>15 Humidity output</p> <p>16 Reverse mode output</p> <p>17 Output managed by time band</p> <p>18 Control output 3 ON/OFF</p> <p>19 Reverse output - dehumidification</p> <p>20 External dehumidifier</p> <p>21 Reverse mode output 2</p>	0	21	/	A	272	R/W	2

	hSn	Start set point variation by time band: hours	0	23	hours	A	223	R/W	0
	MS n	Start set point variation by time band: minutes	0	59	min	A	225	R/W	0
	hSF	End set point variation by time band: hours	0	23	hours	A	224	R/W	0
	MS F	End set point variation by time band: minutes	0	59	min	A	226	R/W	0
	H9	Enable set point variation by time band 0/1=disabled/enabled	0	1	-	D	50	R/W	0
doL	c12	Compressor safety time for door switch 0 = disable door management	0	5	min	I	103	R/W	5
	d8d	Compressor restart time for door switch	c12	240	min	I	104	R/W	30
	A3	Disable door microswitch 0 = door microswitch enabled 1 = door microswitch disabled	0	1	-	D	45	R/W	1
	tLi	Light on with door open	0	240	min	I	105	R/W	120
	A4	Light management	0	1	-	D	7	R/W	0
		0 = door switch + light key - 1 = light key							
GEF	AS1	ON/OFF control 1: control variable configuration 0 Sm 1 Sd1 2 Sr 3 Sv 4 Sd2 5 Sc 6 SA 7 Su 8 probe 2 generic temperature 9 probe 3 generic temperature 10 probe 4 generic temperature 11 probe 5 generic temperature 12 probe 4 generic humidity 13 probe 5 generic humidity 14 probe 5 generic pressure	0	14	-	A	229	R/W	3
	r1S	ON/OFF control 1: mode 0/1=direct/reverse	0	1	-	D	51	R/W	0
	SS1	ON/OFF control 1: set point	- 50.0 0.0 - 200. 0	200.0 100.0 999	°C/°F/ rH%/ bar/psi	A	195	R/W	0
	rS1	ON/OFF control 1: differential	0.1	20.0	°C/°F/ rH%/ bar/psi	A	197	R/W	2
	AL1	ON/OFF control 1: absolute low alarm threshold	- 50.0 0.0 - 200. 0	200.0 100.0 999	°C/°F/ rH%/ bar/psi	A	199	R/W	0

AH1	ON/OFF control 1: absolute high alarm threshold	- 50.0 0.0 -	200.0 100.0 999	°C/°F/ rH%/ bar/psi	A	201	R/W	0
Ad1	ON/OFF control 1: alarm delay	0	250	min	A	231	R/W	0
AS2	ON/OFF control 2: control variable configuration 0 Sm 1 Sd1 2 Sr 3 Sv 4 Sd2 5 Sc 6 SA 7 Su 8 probe 2 generic temperature 9 probe 3 generic temperature 10 probe 4 generic temperature 11 probe 5 generic temperature 12 probe 4 generic humidity 13 probe 5 generic humidity 14 probe 5 generic pressure	0	14	-	A	230	R/W	3
r2S	ON/OFF control 2: mode 0/1=direct/reverse	0	1	-	D	52	R/W	0
SS2	ON/OFF control 2: set point	- 50.0 0.0 -	200.0 100.0 999	°C/°F/ rH%/ bar/psi	A	196	R/W	0
rS2	ON/OFF control 2: differential	0.1	20.0	°C/°F/ rH%/ bar/psi	A	198	R/W	2
AL2	ON/OFF control 2: absolute low alarm threshold	- 50.0 0.0 -	200.0 100.0 999	°C/°F/ rH%/ bar/psi	A	200	R/W	0
AH2	ON/OFF control 2: absolute high alarm threshold	- 50.0 0.0 -	200.0 100.0 999	°C/°F/ rH%/ bar/psi	A	202	R/W	0
Ad2	ON/OFF control 2: alarm delay	0	250	min	A	232	R/W	0

AS3	ON/OFF control 3: control variable configuration 0 Sm 1 Sd1 2 Sr 3 Sv 4 Sd2 5 Sc 6 SA 7 Su 8 probe 2 generic temperature 9 probe 3 generic temperature 10 probe 4 generic temperature 11 probe 5 generic temperature 12 probe 4 generic humidity 13 probe 5 generic humidity 14 probe 5 generic pressure	0	14	-	A	229	R/W	0
r3S	ON/OFF control 3: mode (0/1=direct/reverse)	0	1	-	D	51	R/W	0
SS3	ON/OFF control 3: set point	- 50.0 0.0 - 200.0 0	200.0 100.0 999	°C/°F/ rH%/ bar/psi	A	195	R/W	0
rS3	ON/OFF control 3: differential	0.1	20.0	°C/°F/ rH%/ bar/psi	A	197	R/W	2
AL6	ON/OFF control 3: absolute low alarm threshold	- 50.0 0.0 - 200.0 0	200.0 100.0 999	°C/°F/ rH%/ bar/psi	A	199	R/W	0
AH6	ON/OFF control 3: absolute high alarm threshold	- 50.0 0.0 - 200.0 0	200.0 100.0 999	°C/°F/ rH%/ bar/psi	A	201	R/W	0
Ad6	ON/OFF control 3: alarm delay	0	250	min	A	231	R/W	0
AM1	Modulating control: control variable configuration 0 Sm 1 Sd1 2 Sr 3 Sv 4 Sd2 5 Sc 6 SA 7 Su 8 probe 2 generic temperature 9 probe 3 generic temperature 10 probe 4 generic temperature 11 probe 5 generic temperature 12 probe 4 generic humidity 13 probe 5 generic humidity 14 probe 5 generic pressure	0	14	-	A	233	R/W	3
r1M	Modulating control: mode 0/1=direct/reverse	0	1	-	D	53	R/W	0

SM1	Modulating control: set point	- 50.0 0.0 - 200.0	200.0 100.0 999	°C/°F/ rH%/ bar/psi	A	201	R/W	0
rc1	Modulating control: differential	0.1	20.0	°C/°F/ rH%/ bar/psi	A	204	R/W	2
rM1	Modulating control: modulation range, between min SL1 and max SH1	0.1	40.0	°C/°F/ rH%/ bar/psi	A	205	R/W	2
SL1	Modulating control: min. modulating output value (cut-off)	0.0	SH1	%	A	235	R/W	0
SH1	Modulating control: max. modulating output value	SL1	100.0	%	A	234	R/W	100
AL3	Modulating control: absolute low alarm threshold	- 50.0 0.0 - 200.0	200.0 100.0 999	°C/°F/ rH%/ bar/psi	A	206	R/W	0
AH3	Modulating control: absolute high alarm threshold	- 50.0 0.0 - 200.0	200.0 100.0 999	°C/°F/ rH%/ bar/psi	A	207	R/W	0
Ad3	Modulating control: alarm delay	0	250	min	A	236	R/W	0
AA1	Alarm 1: select source 0 DI2 (with A5=15) 1 Virtual probe (Sv) fault (rE) 2 Probe S1 (Sm) fault (E0) 3 Probe S2 fault (E1) 4 Probe S3 fault (E2) 5 Probe S4 fault (E3) 6 Probe S5 fault (E4) 7 Low pressure alarm (LP) 8 Immediate external alarm (IA) 9 Low temperature alarm (LO) 10 High temperature alarm (HI) 11 High condenser temperature alarm (CHt)	0	11	-	A	237	R/W	0
r1A	Alarm 1: logic 0/1=normally open/normally closed	0	1	-	D	54	R/W	0
Ad4	Alarm 1: delay	0	250	min	A	239	R/W	0
AA2	Alarm 2: select source 0 DI3 (with A9=15) 1 Virtual probe (Sv) fault (rE) 2 Probe S1 (Sm) fault (E0) 3 Probe S2 fault (E1) 4 Probe S3 fault (E2) 5 Probe S4 fault (E3) 6 Probe S5 fault (E4) 7 Low pressure alarm (LP) 8 Immediate external alarm (IA) 9 Low temperature alarm (LO) 10 High temperature alarm (HI) 11 High condenser temperature alarm (CHt)	0	11	-	A	238	R/W	0

	r2A	Alarm 2: logic 0/1=normally open/normally closed	0	1	-	D	55	R/W	0
	Ad5	Alarm 2: delay	0	250	min	A	240	R/W	0
EVD	P1t	S1 probe type 0 CUSTOM 1 -1 ... 4.2 barg 2 0.4 ... 9.3 barg 3 -1 ... 9.3 barg 4 0 ... 17.3 barg 5 0.85 ...34.2 barg 6 0 ... 34.5 barg 7 0 ... 45 barg 8 -1 ... 12.8 barg 9 0 ... 20.7 barg 10 1.86 ... 43.0 barg 11 RESERVED 12 0 ... 60.0 barg 13 0 ... 90.0 barg							12
	IL1	MIN value of ALARM of S1 probe	- 20/- 121	IH1	°C / ° F	A	303	R/W	0
	IH1	MAX value of ALARM of S1 probe	IL1	200	°C / ° F	A	304	R/W	60
	PrE	Main regulation type 0 CUSTOM 1 Centralised cabinet /cold room 2 Self contained cabinet /cold room 3 Perturbed cabinet /cold room 4 Subcritical CO2 cabinet /cold room 5 R404A condenser for subcritical CO2 6 AC or chiller with plate evaporator 7 AC or chiller with shell tube evaporator 8 AC or chiller with coil evaporator 9 AC or chiller with variable cooling capacity 10 AC or chiller perturbed unit	1	4	-	I	148	R/W	2
	PH	Refrigerant type 1 R22 21 R245FA 2 R134a 22 R407F 3 R404A 23 R32 4 R407C 24 HTR01 5 R410A 25 HTR02 6 R507A 26 R23 7 R290 27 R1234yf 8 R600 28 R1234ze 9 R600A 29 R455A 10 R717 30 R170 11 R744 31 R442A 12 R728 32 R447A 13 R1270 33 R448A 14 R417A 34 R449A 15 R422D 35 R450A 16 R413A 36 R452A 17 R422A 37 R508B 18 R423A 38 R452B 19 R407A 39 R513A 20 R427A 40 R454B	1	40	-	I	146	R/W	11
	P3	Superheat setpoint	-72	324	K	A	35	R/W	8

P4	Proportional gain	0	800	-	A	27	R/W	15
P5	Integral time	0	999	sec	A	159	R/W	150
P6	Derivative time	0	800	sec	A	28	R/W	5
P7	LowSH: threshold low superheat	-72	324	K	A	36	R/W	3
P8	Low Superheat protection integral time	0	800	sec	A	29	R/W	600
P9	LowSH: low superheat alarm delay	0	999	sec	A	161	R/W	600
PL1	LOP: threshold for low temperature of evaporation	-60	200	°C / ° F	A	41	R/W	-40
PL2	LOP: integral time	0	800	sec	A	30	R/W	600
PL3	LOP: low evaporation temperature alarm delay	0	999	sec	A	162	R/W	600
PM 1	MOP: threshold for low temperature of evaporation	-60	200	°C / ° F	A	38	R/W	15
PM 2	MOP: integral time	0	800	sec	A	31	R/W	600
PM 3	MOP: low evaporation temperature alarm delay	0	999	sec	I	163	R/W	10
PM 4	MOP: low evaporation temperature INHIBITION THRESHOLD	-60	200	°C / ° F	A	306	R/W	-10
PT1	Low suction temperature: THRESHOLD	-60	200	°C / ° F	A	34	R/W	-45
cP1	Open valve startup (percentage)	0	100	%	A	157	R/W	30
Pdd	Post defrost delay, (only for single driver)	0	60	min	A	158	R/W	10
PSb	Valve position in stand-by	0	100	step	A	174	R/W	0
PM P	Enable manual positioning	0	1	-	D	38	R/W	0
PM u	Manual valve positioning	0	999	step	I	173	R/W	0
IU3	Valve regulation steps (only EVD ICE) 1=480 / 2=960	1	2	-	I	184	R/W	1
PPT	Pre positioning time	0	18000	sec	I		R/W	6
PS M	Enable smooth lines (0=NO - 1=YES)	0	1	/	D	62	R/W	1
PHS	Maximum smooth lines offset	0.0	50.0	°C / ° F	A	287	R/W	6
PLt	Stop smooth lines offset	0.0	10.0	°C / ° F	A	286	R/W	2
PSP	Smooth lines proportional coefficient	0.0	100.0	°C / ° F	A	288	R/W	5
PSI	Smooth lines integral time	0	1200	s	A	289	R/W	120
PSd	Smooth lines derivative time	0	100	s	A	290	R/W	0
ICG	Reset EVD setting 0 -> 1 Reset all EVD parameters	0	1	-	D	64	R/W	0
Pnr	Reset EVD setting 0 -> 1 Reset all EVD parameters	0	1	-	D	64	R/W	0

Ultra 3PH	cH1	3PH module serial address	1	247	-	I	177	R/W	1
	cH2	3PH module offset serial address	0	232	-	I	178	R/W	0
	cA1	Sd1 probe connection 0 = in UltraCella -1 = in 3PH module	0	1	-	D	40	R/W	0
	cA2	Sd2 probe connection 0 = in UltraCell -1 = in 3PH module	0	1	-	D	41	R/W	0
	cEn	Enable 3PH mod. 0 = disable - 1 = enable	0	1	-	D	43	R/W	0
Out	H15	Output R1 configuration 0 Compressor 1 Defrost 2 Fan 3 Light 4 AUX 1 5 AUX 2 6 AUX 3 7 AUX 4	0	7	/	A	273	R/W	5
	H16	Output R2 configuration 0 Compressor 1 Defrost 2 Fan 3 Light 4 AUX 1 5 AUX 2 6 AUX 3 7 AUX 4	0	7	/	A	274	R/W	4
	H17	Output R3 configuration 0 Compressor 1 Defrost 2 Fan 3 Light 4 AUX 1 5 AUX 2 6 AUX 3 7 AUX 4	0	7	/	A	275	R/W	3
	H18	Output R4 configuration 0 Compressor 1 Defrost 2 Fan 3 Light 4 AUX 1 5 AUX 2 6 AUX 3 7 AUX 4	0	7	/	A	276	R/W	2
	H19	Output R5 configuration 0 Compressor 1 Defrost 2 Fan 3 Light 4 AUX 1 5 AUX 2 6 AUX 3 7 AUX 4	0	7	/	A	277	R/W	1

	H20	Output R6 configuration 0 Compressor 1 Defrost 2 Fan 3 Light 4 AUX 1 5 AUX 2 6 AUX 3 7 AUX 4	0	7	/	A	278	R/W	0
HUM	StH	Humidity set point	0.0	100.0	%rH	A	19	R/W	90
	rdH	Humidity differential	0.1	20.0	%rH	A	20	R/W	5
	rrH	Dehumidification differential	0.0	50.0	%	A	298	R/W	5
	rnH	Humidity dead band	0.0	50.0	%	A	299	R/W	5
	TLL	Minimum temperature to enable humidity control	- 60.0	60.0	°C / ° F	A	295	R/W	0
	THL	Maximum temperature to enable humidity control	- 60.0	60.0	°C / ° F	A	296	R/W	0
	TdL	Temperature differential to enable humidity control	0.0	20.0	°C / ° F	A	297	R/W	0
	r5	Humidity set point offset	- 50.0	50.0	%	A	302	R/W	0
	F4	Humidity output during defrost	0	1	-	D	28	R/W	1
		0/1 = ON/OFF							
	U1	Humidity control duty cycle ON time	0	120	min	A	300	R/W	10
	U2	Humidity control duty cycle OFF time	0	120	min	A	301	R/W	60
	F11	Fan speed during humidification	0	100	%	A	293	R/W	40
	F12	Minimum fan speed during humidification	0	100	%	A	294	R/W	10
HACC P	HA	Date/time of last HA alarm: day	1	7	day	I	29	R	-
		Date/time of last HA alarm: hour	1	23	hour	I	30	R	-
		Date/time of last HA alarm: minute	1	59	min	I	31	R	-
	HA1	Date/time of second last HA alarm: day	1	7	day	I	32	R	-
		Date/time of second last HA alarm: hour	1	23	hour	I	33	R	-
		Date/time of second last HA alarm: minute	1	59	min	I	34	R	-

HA2	Date/time of third last HA alarm: day	1	7	day	I	35	R	-
	Date/time of third last HA alarm: hour	1	23	hour	I	36	R	-
	Date/time of third last HA alarm: minute	1	59	min	I	37	R	-
HA n	Number of HA alarms	1	15	-	I	53	R	-
HF	Date/time of last HF alarm: day	1	7	day	I	38	R	-
	Date/time of last HF alarm: hour	1	23	hour	I	39	R	-
	Date/time of last HF alarm: minute	1	59	min	I	40	R	-
HF1	Date/time of second last HF alarm: day	1	7	day	I	43	R	-
	Date/time of second last HF alarm: hour	1	23	hour	I	44	R	-
	Date/time of second last HF alarm: minute	1	59	min	I	45	R	-
HF2	Date/time of third last HF alarm: day	1	7	day	I	48	R	-
	Date/time of third last HF alarm: hour	1	23	hour	I	49	R	-
	Date/time of third last HF alarm: minute	1	59	min	I	50	R	-
HFn	Number of HF alarms	1	15	-	I	54	R	-
Hcr	Reset HACCP alarms	0	1	-	D	12	R/W	0

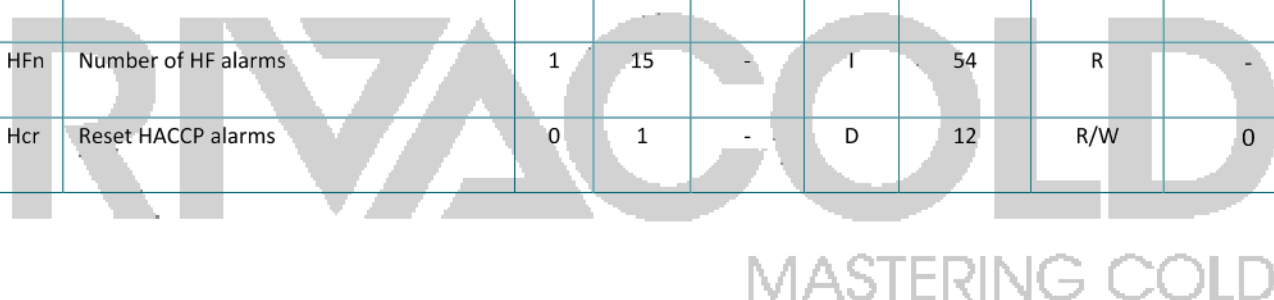

4.6.15. Main faults and alarms

FAULTS AND MAINTENANCE

FAULT	PROBABLE CAUSE	ACTION REQUIRED
The compressor does not start	High pressure intervention	See fault "Too low aspiration pressure"
	Minimum Off time between more restarting not passed yet	Wait for the end of timing
	Intervention of the general automatic switch	Check the reason of the intervention and reset the switch
	Intervention of the internal thermal protection	Check the reason of the intervention of the thermal protection
	Intervention of the magnetothermic compressor	Reset the switch
The compressor works continuously	Electronic control or other faulted electronic devices	See faults "Cooling capacity too big", "Insufficient cooling capacity"
	Insufficient gas charge	Load the gas in the system
	Evaporator locked or ice presence	Clean and defrost the evaporators
Unusual noise from the compressor	Incorrect mounting	Check the tightening of the fixing bolts
	Aspiration of liquid	Check and reset the thermostatic valve. Check that the solenoid of the liquid is closed during the unit stopping.
	Temperature sensor of the valve not properly fixed or fixed in a wrong way	Check the position of the temperature sensor of the valve
	Emulsion in the oil of the carter	Incorrect lubrication. See fault "Oil temperature too low" and "Very foaming oil after compressor stopping"
Aspiration temperature too high	Very high gas overheating (above 20K)	Check and adjust the thermostatic valve in the evaporator
Aspiration temperature too low	Liquid in the aspiration line	Adjust the thermostatic valve
	Sensor not properly connected or wrongly positioned	Check if it is positioned in contact with the aspiration line and possibly replace it
Aspiration pressure too low	A lot of oil in the evaporator	Discharge the oil from the evaporator
	Liquid line filter obstructed	Check and replace the liquid line filter
	High overheating during aspiration	Adjust the thermostatic valve
	Insufficient gas charge	Load the gas in the system
Aspiration pressure too high	Restarting after defrosting	Wait for confirmation
	Compression problems	Compressor replacement

FAULT	PROBABLE CAUSE	ACTION REQUIRED
Gas cooler pressure too high	Insufficient air flow in the gas cooler	<i>Clean the gas cooler and check the fans.</i>
	Excessive gas charge	<i>Discharge the liquid from the receiver</i>
	Air or gas non condensible inside the HP circuit	<i>Discharge, empty and recharge the unit</i>
Gas cooler pressure too low	Fans adjustment incorrectly set	<i>Adjust the fan adjustment parameters</i>
Discharge temperature too high	Too high overheating during aspiration	<i>Adjust the thermostatic valve</i>
	Internal By-pass	<i>Check the compressor</i>
Oil temperature too high	Too high overheating during aspiration	<i>Check and adjust the thermostatic valve in the evaporator</i>
Oil temperature too low	Oil return together with the refrigerant liquid	<i>Adjust the thermostatic valve</i>
Cooling capacity too big	Problem with the electronic control or with other devices	<i>Replace, repair and reset them</i>
Insufficient cooling capacity	Problem with the electronic control or with other devices	<i>Replace, repair and reset them</i>
Very foaming oil after compressor stopping	Thermostatic valve (liquid return from aspiration)	<i>Check the thermostatic valve</i>
	Temperature sensor of the valve not properly fixed or fixed in a wrong way	<i>Check the position of the temperature sensor of the valve</i>
	Resistance carter fault	<i>Replace the carter resistance</i>



 MASTERING COLD

4.6.16. DC Cella system alarms list

ALARM CODE	DESCRIPTION	DEVICE	DEVICE ALARM CODE	RESET	ACTIONS
H43	Main function probe A in the sheet 1 broken or disconnected	HECU	ALA04	Automatic	Relative functions disabled
H44	Main function probe B in the sheet 1 broken or disconnected	HECU	ALA05	Automatic	Relative functions disabled
H45	Main function probe C in the sheet 1 broken or disconnected	HECU	ALA06	Automatic	Relative functions disabled
H46	Main function probe D in the sheet 1 broken or disconnected	HECU	ALA07	Automatic	Relative functions disabled
H47	Main function probe E in the sheet 1 broken or disconnected	HECU	ALA08	Automatic	Relative functions disabled
H48	Press. probe Backup condensation broken or disconnected	HECU	ALA31	Automatic	Relative functions disabled
H49	Press. probe Backup aspiration broken or disconnected	HECU	ALA33	Automatic	Relative functions disabled
H50	Press. probe Steam injection broken or disconnected	HECU	ALA46	Automatic	Relative functions disabled
H51	Temp. probe Steam injection broken or disconnected	HECU	ALA47	Automatic	Relative functions disabled
H52	Backup compressor alarm	HECU	ALC05	Man./Autom.	Compressor switching off
H53	High temp. alarm General function thermostat 1-5	HECU	ALG11	Man./Autom.	-
H54	Low temp. alarm General function thermostat 1-5	HECU	ALG15	Man./Autom.	-
H55	High temp. alarm General function thermostat 6-7	HECU	ALG19	Man./Autom.	-
H56	Low temp. alarm General function thermostat 6-7	HECU	ALG23	Man./Autom.	-

ALARM CODE	DESCRIPTION	DEVICE	DEVICE ALARM CODE	RESET	ACTIONS
H57	High temp. alarm General function thermostat 8-9	HECU	ALG27	Man./Autom.	-
H58	Low temp. alarm General function thermostat 8-9	HECU	ALG28	Man./Autom.	-
H59	Compressor functioning hours	HECU	ALT01	Manual	-
H02	Alarm CDU 02 Discharge temp. probe broken or disconnected	HECU	ALA01	Automatic	Relative functions disabled
H03	Alarm CDU 03 Press. probe Condensation broken or disconnected	HECU	ALA02	Automatic	Relative functions disabled
H04	Alarm CDU 04 External temp. Probe broken or disconnected	HECU	ALA03	Automatic	Relative functions disabled
H05	Alarm CDU 05 Asp. press. Probe broken or disconnected	HECU	ALA24	Automatic	Relative functions disabled
H06	Alarm CDU 06 Asp.temp. Probe broken or disconnected.	HECU	ALA25	Automatic	Relative functions disabled
H07	Alarm CDU 07 Cell temp. Probe broken or disconnected	HECU	ALA26	Automatic	Relative functions disabled
H08	Alarm CDU 08 Low condensation pressure from pressure switch	HECU	ALB01	Semi-automatic	Compressor switching off
H09	Alarm CDU 09 High condensation pressure from pressure switch	HECU	ALB02	Man./Autom.	Compressor switching off
H10	Alarm CDU 10 Low condensation pressure alarm	HECU	ALB03	Automatic	Fans forcing at 0%
H11	Alarm CDU 11 High condensation pressure alarm	HECU	ALB04	Automatic	Fans forcing at 100% (5 min.) and compressor switching off
H15	Alarm CDU 15 High aspiration pressure alarm	HECU	ALB15	Automatic	-

ALARM CODE	DESCRIPTION	DEVICE	DEVICE ALARM CODE	RESET	ACTIONS
H16	Alarm CDU 16 Low aspiration pressure alarm	HECU	ALB16	Automatic	-
H19	Alarm CDU 19 Alarm 1 compressor 1	HECU	ALC01	Man./Autom.	Compressor switching off
H20	Alarm CDU 20 Alarm 2 compressor 1	HECU	ALC02	Man./Autom.	Compressor switching off
H23	Alarm CDU 23 Watch sheet error	HECU	ALG01	Automatic	Relative functions disabled
H24	Alarm CDU 24 Extended memory error	HECU	ALG02	Automatic	Relative functions disabled
H26	Alarm CDU 26 Low overheating alarm	HECU	ALT15	Settable	Compressor switching off
H27	Alarm CDU 27 DSH Low liquid return	HECU	ALT19	Settable	Compressor switching off
H01	Alarm CDU 01 Absence adjusting probe	HECU	ALU02	Automatic	Unit switching off
H32	Alarm CDU 32 Device Power+ No.1 offline	HECU	ALW24	Semi-automatic	Compressor switching off
H43	Alarm CDU 43 Inverter Power+ No.1 Alarm	HECU	ALW25	Semi-automatic	Compressor switching off
H33	Alarm CDU 33 Compressor 1 starting failed (tempt./max.:	HECU	ALW26	Semi-automatic	-
H34	Alarm CDU 34 Envelop area Compressor 1 Alarm	HECU	ALW27	Semi-automatic	Compressor switching off
H35	Alarm CDU 35 High temperature gas discharge compressor 1	HECU	ALW28	Automatic	-
H37	Alarm CDU 37 Inverter model non compatible	HECU	ALW30	Automatic	-
H25	Alarm CDU 25 Non reliable condition No DC Cella connection	HECU	ALG03	Automatic	Emergency Functioning (for 24h)

ALARM CODE	DESCRIPTION	DEVICE	DEVICE ALARM CODE	RESET	ACTIONS
H28	Alarm CDU 28 High pressure prevention	HECU	ALW01	Automatic	Compressor speed reduction
H31	Alarm CDU 31 High temperature prevention	HECU	ALW23	Automatic	Compressor speed reduction
H38	Alarm CDU 38 DC CELLA device offline	HECU	ALW37	Automatic	Emergency Functioning (for 24h)
H41	Alarm CDU 41 Liq.return from DC CELLA offline - flush	HECU	ALZ06	Automatic	-
H42	Alarm CDU 42 Carel EXV Valve not configured in DC CELLA	HECU	ALZ08	Automatic	-
HLE	CDU offline	DC Cella Controller	HLE	Automatic	Emergency Functioning (for 24h)
HNC	CDU non compatible	DC Cella Controller	HNC	Automatic	Adjustment switching off
RE	Virtual probe faulted, check Sm and Sr probes	DC Cella Controller	RE	Automatic	Duty Cycle Adjustment
E0	Probe 1 broken or disconnected	DC Cella Controller	E0	Automatic	Duty Cycle Adjustment
E1	Probe 2 broken or disconnected	DC Cella Controller	E1	Automatic	-
E2	Probe 3 broken or disconnected	DC Cella Controller	E2	Automatic	-
E3	Probe 4 broken or disconnected	DC Cella Controller	E3	Automatic	-
E4	Probe 5 broken or disconnected	DC Cella Controller	E4	Automatic	-
LO	Low temperature alarm	DC Cella Controller	LO	Automatic	-
HI	High temperature alarm	DC Cella Controller	HI	Automatic	-
IA	Immediate alarm due to external contact	DC Cella Controller	IA	Automatic	Duty Cycle (A6) Adjustment
DA	Delayed alarm due to external contact	DC Cella Controller	DA	Automatic	Duty Cycle (A6) Adjustment
dEF	Defrosting in progress	DC Cella Controller	dEF	Automatic	Defrosting enabled
Ed1	Defrosting on Evaporator 1 finished for time-out	DC Cella Controller	Ed1	Automatic	-

ALARM CODE	DESCRIPTION	DEVICE	DEVICE ALARM CODE	RESET	ACTIONS
PD	<i>Pump-down maximum time alarm</i>	DC Cella Controller	PD	<i>Automatic</i>	-
LP	<i>Low pressure alarm</i>	DC Cella Controller	LP	<i>Automatic</i>	<i>Adjustment switching off</i>
ATS	<i>Automatic starting in pump-down</i>	DC Cella Controller	ATS	<i>Man./Autom.</i>	-
DOR	<i>Door open for long time alarm</i>	DC Cella Controller	DOR	<i>Automatic</i>	-
ETC	<i>Watch sheet error</i>	DC Cella Controller	ETC	<i>Automatic</i>	-
EE	<i>EEprom unit parameters error</i>	DC Cella Controller	EE	<i>Automatic</i>	-
EF	<i>EEprom operating parameters error</i>	DC Cella Controller	EF	<i>Automatic</i>	-
HA	<i>HA HACCP Alarm</i>	DC Cella Controller	HA	<i>Manual</i>	-
HF	<i>HF HACCP Alarm</i>	DC Cella Controller	HF	<i>Manual</i>	-
CHT	<i>High temp. condensation pre-alarm</i>	DC Cella Controller	CHT		
CHT	<i>High temperature condensation alarm</i>	DC Cella Controller	CHT	<i>Manual</i>	<i>Adjustment switching off</i>
LOG	<i>Error in the exported file of the recorder temperatures</i>	DC Cella Controller	LOG	<i>Automatic</i>	-
DNL	<i>Parameters download error</i>	DC Cella Controller	DNL	<i>Automatic</i>	-
UPD	<i>Parameters upload error</i>	DC Cella Controller	UPD	<i>Automatic</i>	-
ALM	<i>Error in the alarms exportation</i>	DC Cella Controller	ALM	<i>Automatic</i>	-
SOF	<i>Software updating error</i>	DC Cella Controller	SOF	<i>Automatic</i>	-
AUH	<i>High humidity alarm</i>	DC Cella Controller	AUH	<i>Automatic</i>	-
AUL	<i>Low humidity alarm</i>	DC Cella Controller	AUL	<i>Automatic</i>	-
GH1	<i>High value generic alarm Generic function: Thermostat 1</i>	DC Cella Controller	GH1	<i>Automatic</i>	-
GL1	<i>Low value generic alarm Generic function: Thermostat 1</i>	DC Cella Controller	GL1	<i>Automatic</i>	-

ALARM CODE	DESCRIPTION	DEVICE	DEVICE ALARM CODE	RESET	ACTIONS
GH2	High value generic alarm Generic function: Thermostat 2	DC Cella Controller	GH2	Automatic	-
GL2	Low value generic alarm Generic function: Thermostat 2	DC Cella Controller	GL2	Automatic	-
GH3	High value generic alarm Generic function: Modulation 1	DC Cella Controller	GH3	Automatic	-
GL3	Low value generic alarm Generic function: Modulation 1	DC Cella Controller	GL3	Automatic	-
GA1	General function alarm: Alarm 1	DC Cella Controller	GA1	Automatic	-
GA2	General function alarm: Alarm 1	DC Cella Controller	GA2	Automatic	-
ILE	EVD ICE module error: EVD device offline	DC Cella Controller	E6	Automatic	Adjustment based on Dig. Inp. EVD Ice
IEC	EVD ICE module error: Configuration error (IPE=1 and ICG = 0)	DC Cella Controller	IEC	Automatic	Adjustment switching off
IEM	EVD ICE module error: Correspondence missing error	DC Cella Controller	IEM	Manual	-
GH6	High value generic alarm Generic function: Thermostat 3	DC Cella Controller	GH6	Automatic	-
GL6	Low value generic alarm Generic function: Thermostat 3	DC Cella Controller	GL6	Automatic	-
SA	Serious alarm due to external contact	DC Cella Controller	SA	Automatic	Adjustment switching off
EFU	EVD ICE module error: Firmware EVD compatibility	DC Cella Controller	EFU	Automatic	Adjustment switching off

ALARM CODE	DESCRIPTION	DEVICE	DEVICE ALARM CODE	RESET	ACTIONS
ECN	<i>EVD ICE module error: Configuration failed</i>	DC Cella Controller	ECN	<i>Automatic</i>	<i>Adjustment switching off</i>
SHA	<i>EVD ICE module error: Low overheating protection</i>	EVD ICE	E3	<i>Automatic</i>	<i>Opening/closure valve adjustment</i>
LOA	<i>EVD ICE module error: Low evaporation temperature</i>	EVD ICE	E2	<i>Automatic</i>	<i>Opening/closure valve adjustment</i>
MOA	<i>EVD ICE module error: Evaporation high temperature</i>	EVD ICE	E1	<i>Automatic</i>	<i>Opening/closure valve adjustment</i>
LSA	<i>EVD ICE module error: Aspiration low temperature</i>	EVD ICE	E4	<i>Automatic</i>	-
ES1	<i>EVD ICE module error: Probe S1 fault</i>	EVD ICE	A1	<i>Automatic</i>	<i>Valve closure</i>
ES2	<i>EVD ICE module error: Probe S2 fault</i>	EVD ICE	A2	<i>Automatic</i>	<i>Valve closure</i>
BAT	<i>EVD ICE module error: Faulted or low battery</i>	EVD ICE	E7	<i>Automatic</i>	-
EEE	<i>EVD ICE module error: EEPROM fault</i>	EVD ICE	EE	<i>Replace driver</i>	<i>Adjustment locked</i>
EIC	<i>EVD ICE module error: Incomplete valve closure</i>	EVD ICE	E8	<i>Manual</i>	<i>Valve closure</i>
EEC	<i>EVD ICE module error: Emergency valve closing</i>	EVD ICE	E5	<i>Automatic</i>	<i>Valve closure</i>



 MASTERING COLD

4.7. Storage

If it is necessary to keep the machine for a certain period of time before installing it, it is recommended to protect it adequately and to store it in a suitable environment, with the following characteristics:

- external surfaces resistant to atmospheric agents;
- no access permitted to unauthorised persons;
- with the following environmental conditions:
 - well ventilated;
 - ambient temperature between -10 °C and +40 °C;
 - relative air humidity between 30% and 80%.



ATTENTION: Do not remove the potential packagings present for some machine components. Take suitable precautions to protect the exposed parts.

4.8. Disassembling

If it is necessary to uninstall the machine, proceed in the reverse order with respect to the installation sequence provided in Paragraph 4.4 "Installation". The gas removal shall occur in the aspiration lines, keeping positive and negative the active utility (if present). It is recommended to remove the gas from the liquid line due to the instantaneous ice forming for pressures lower than 5.6 bar.



DANGER: The operations shall be exclusively performed by qualified and specifically trained technicians. The Manufacturer declines all responsibility for operations carried out without respecting the safety regulations, by unqualified operators and without compliance with the specifications of this manual.

RIVACOLD
MASTERING COLD

5. Maintenance and dismantling

To guarantee maximum reliability on the machine and to avoid dangerous conditions, carefully follow the instructions and warnings on the following pages.

Periodic maintenance and correct use are essential factors to guarantee the full efficiency and safety of the machine.

The maintenance interventions and the prescribed ones allow to prevent problems due to the safety measures deterioration or machine downtimes, in such a way indications about the necessary potential extraordinary operations can be provided.



DANGER: The following operations must out be carried only by qualified and specifically trained technicians. The Manufacturer declines all responsibility for operations carried out without respecting the safety regulations, by unqualified operators and without compliance with the specifications of this manual.



DANGER: Before performing any maintenance or cleaning intervention reported in this paragraph, it is necessary to disconnect the MACHINE from the electric power supply acting on the main disconnecter switch placed on the condensing unit panel which closes the electric equipment. The disconnecter must be locked in the open position with a padlock.



ATTENTION: During operations, the operator must use all the necessary Personal Protective Equipment (PPE).



DANGER: During the maintenance and demolition of the machine it is necessary to follow the warnings listed below.



DANGER: Before performing any type of intervention, it is necessary to check the absence of leakages of R744 (CO₂) by means of specific gas detector.

- It is necessary to warn, using appropriate signs, of the intervention on the machine to prevent any undesired operation on the same.
- During the interventions only authorised personnel may access the work area.
- Dismount only the indeed necessary parts of the machine to perform the specific maintenance operation. Furthermore, before delivering the machine to the operators, it is necessary to check its integrity and functioning.
- Operate as much as possible on the machine and on the piping, only after having emptied them out; before restarting the machine, ensure an accurate cleaning of the system.
- Do not, for any reason, use petrol, solvents, corrosive products or flammable fluids to clean parts, but use neutral and approved non-flammable and non-toxic commercial detergents.
- Do not make changes, transformations or applications to the machine that could compromise safety without first obtaining written authorisation from the manufacturer.
- All environmental impact materials that need to be removed as a result of maintenance must be disposed of in accordance with current regulations.



ATTENTION: For the disposal of materials with high environmental impact, if necessary, use specialist facilities.

Checking the availability of the material

60 days prior to the date determined for interventions of maintenance, perform a detailed examination of the material necessary:

3. check if the material is on the stock,
4. if necessary, ask the manufacturer's Technical Office for the missing parts at least **30 days** in advance.

5.1. Maintenance and cleaning



DANGER: the Manufacturer cannot be held in any way liable for any damage caused to property or persons due to incorrect or incomplete maintenance.



DANGER: Before performing all the foreseen ordinary maintenance interventions, ensure that the machine is disconnected from power supply. In addition, wait for the cooling of hot surfaces.



ATTENTION: In the event the machine parts require replacement, use original spares only.



ATTENTION: any brazing operations in the products must be carried out by qualified personnel.

As regards the specific maintenance and cleaning phase of each device constituting the machine, please consult the relative manuals: Condensing unit CO₂NNEXT (code 99215071), Evaporators (code 99212060-99212061).

5.1.1. Interventions and relative periodicity

ATTENTION: Please, read carefully the manuals of the individual components constituting the machine and perform the interventions required for each of them.



Evaporators (code 99212060-99212061)

Condensing unit CO₂NNEXT (code 99215071).

RIVACOLD
MASTERING COLD

5.2. Disassembly and demolition

See the instructions provided at the beginning of Chapter 5 regarding the warnings and the Personal Protective Equipment to be used.

5.2.1. Disassembly

If the MACHINE has to be disassembled, follow the procedure indicated below.

5. Isolate the machine from power supply.
6. Referring to Paragraph 4.8. - Uninstallation of the Chapter 4 - Transportation and Installation, uninstall the MACHINE. In addition, contact the Manufacturer's Technical Offices to obtain the necessary assistance during this intervention.
7. To proceed with handling of the MACHINE, operate according to the instructions given in Paragraph 4.3 - Transport and Handling of Chapter 4 - Transport and Installation.
8. Prepare the components appropriately according to the fact that they must be transported to another location (refer to Section 4.3 - Transport and Handling of Chapter 4 - Transport and Installation), which must be stored (refer to Section 4.7 - Storage of Chapter 4 - Transport and Installation) or which must be demolished (refer to Section 5.2.2 - Dismantling and Disposal).

5.2.2. Dismantling and disposal

When the machine has ended its life cycle, before the final disposal, a series of operations have to be carried out to minimise the environmental impact related to disposal of the machine components, as required by the standards in force on waste disposal.

These operations are:

4. Separate and store the polluting parts:
 - c) separate the parts that could cause pollution;
 - d) select the materials so as to ease recycling; send them to differentiated waste disposal centres (in particular plastic or rubber parts).
5. The gas contained in the system **must not** be dispersed into the environment. It is advisable to dispose of the unit only at specialist collection centres and not as normal scrap iron, respecting the current regulations.
6. Once the removal and storage of the pollutants have been completed, use specialist facilities for the disposal of the outer frames.

ATTENTION: When demolishing the machine, it is necessary to make unusable both the identification plate of each component of the machine and the relative technical documentation.

The Customer may return these items to the Technical Office of the Manufacturer, which will provide for their destruction.

These elements cannot be preserved in inaccessible places.

At the end of the intervention inform the Technical Office of the Manufacturer on having scrapped the machine.



6. Troubleshooting

As regards the troubleshooting, refer to the individual manuals of the partly-completed machines which constitute the machine:

- Condensing unit CO₂NNEXT (code 99215071).
- Evaporators (code 99212060-99212061)



NOTE: For further information about the functions and the control characteristics, consult the document “UltraCella Manual +0300083” available on the website **HYPERLINK:**

<http://www.Carel.com> www.Carel.com.

RIVACOLD
MASTERING COLD

7. Annexes

Instruction manuals:

- Condensing unit - CO₂NNEXT (code 99215071).
- Evaporators (code 99212060-99212061)

RIVACOLD
MASTERING COLD

RIVACOLD

MASTERING COLD



RIVACOLD s.r.l.
Via Sicilia, 7 - Fraz. Montecchio - 61022 Vallefoglia (PU) - Italia
Tel. +39 0721 919911 - Fax. +39 0721 490015
info@rivacold.com - www.rivacold.com

